



Intel® TeamStation™
System
Version 4.0a

Upgrade Guide

IMPORTANT

This upgrade is for the Intel® TeamStation™ System, Version 4.0 only.

If you have Version 4.0.1, DO NOT install this upgrade. Contact your dealer for the correct upgrade package.

To find the software version number, select About TeamStation System from the System menu.

The Intel TeamStation System, Version 4.0a, is a state-of-the-art 384 Kbps video conferencing system. Your Version 4.0a upgrade kit contains:

- Enhanced software that enables 384 Kbps conferencing
- A new ISDN board with an onboard inverse multiplexer
- ISDN cables
- Additional 32 Mbytes of memory to support Version 4.0a enhancements running on a Version 4.0 system
- Updated documentation

Upgrading your system's hardware and software takes approximately 2 hours. In addition, budget sufficient time to back up and restore data and user applications, and (optionally) for LAN configuration and to add TCP/IP.



How to get free installation of this upgrade

Full installation instructions are included in this Upgrade Guide. By following those instructions, you should be able to conveniently complete the installation. However, you can arrange for an Intel on-site representative to install the upgrade for you at no charge.

Please review the instructions in this Upgrade Guide to help you decide which option will work best for you: self install or free install by an Intel representative.

To receive a free installation

- 1** All of the following must be faxed to Intel Customer Support Services at (503) 264-4002:
 - Your name, company name, address, phone number and fax number
 - Your request for free installation
 - A copy of your proof of purchase (invoice or sales receipt) of the Version 4.0a upgrade
- 2** Intel will fax an installation checklist to your attention for completion.
- 3** Complete the checklist and return it to Intel Customer Support Services at (503) 264-4002 for readiness review.
- 4** An Intel Customer Support Engineer will contact you within one business day after receiving your completed checklist to review it for installation readiness.
- 5** One business day after readiness is verified, you will receive a call from an Intel on-site representative to schedule an installation appointment.
- 6** If you have any questions, please call (888) 547-7641.

This free offer is only available for applications completed before March 31, 1999.

1 Note system settings and back up files

The upgrade process installs new hard drive contents on your system. All data files on your current system will be lost during the upgrade process, so you must back up any files you wish to use when the upgrade is complete.

Settings

Write down the system settings that you'd like to duplicate on the upgraded system. For example:

- If the system is on a **LAN network**, note the LAN configuration, including computer name, drive mappings, and TCP/IP configuration (if used). Look in the Windows* Network dialog, accessible from the Windows Control Panel, and in Windows Explorer.
- If the system uses a **Document Server** that resides on another Intel TeamStation System or Web server, note the IP Address or DNS name for the Document Server.
 - 1 Log on as "Administrator".
 - 2 Select Start>Intel TeamStation System Administrator>Intel TeamStation System AdminTools.
 - 3 Click the **Document Server Setup** tab.
 - 4 Note the IP Address or DNS name for the Document Server.

Files

Back up files that you want to transfer to the upgraded system. Back up to diskettes, or connect your existing system to the network and back up to a network drive. We suggest backing up:

- The Intel TeamStation system's directory of numbers (Dial List):
C:\Program Files\BizVideo\tsdir.ini
- Any documents saved in the local Document Server directory:
C:\Apache\WWWRoot\Document Server
- Any files received during a conference that have been saved on the system in
C:\Received files
- Any other documents stored on the system

Applications

Make sure you have CDs or program diskettes available to reinstall any user applications you'll want on the upgraded system.

2 Install new ISDN board and memory

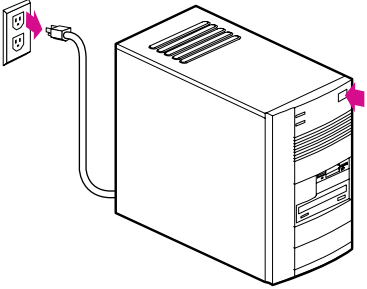
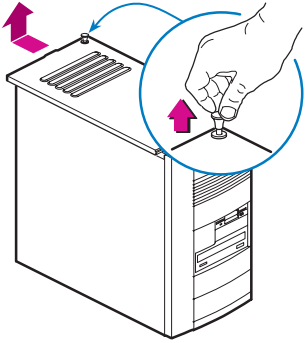
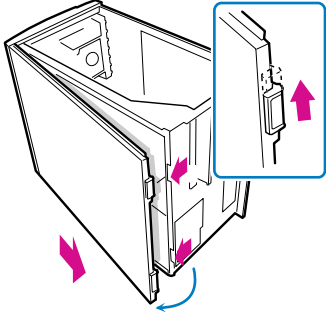
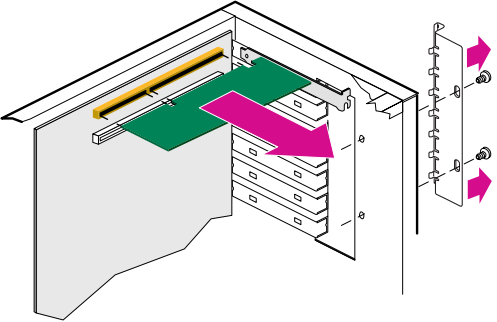
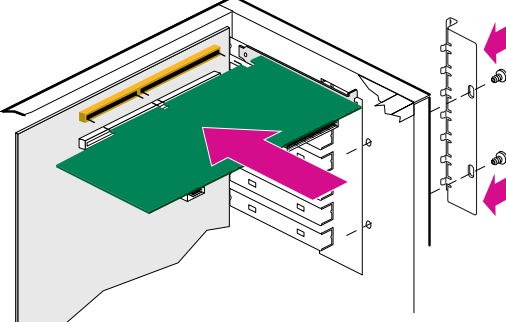
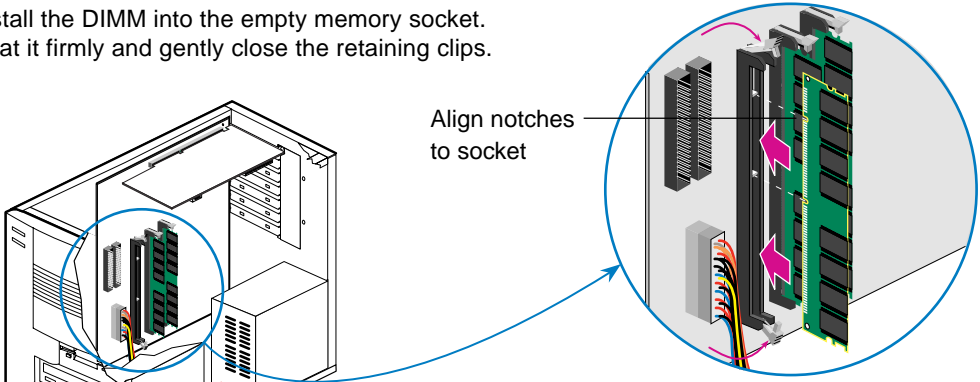
<p>1 Turn off the computer. Disconnect the power and peripherals.</p> 	<p>2 Remove the plastic screw and remove the cover.</p> 	<p>3 Slide the two locking tabs at the rear of the chassis up and remove the side panel.</p> 
<p>4 Remove the old ISDN board.</p> 		<p>5 Insert the new ISDN board.</p>  <p>Caution Static electricity can damage the board. Ground yourself by touching the computer's metal back before handling the board.</p>
<p>6 Install the DIMM into the empty memory socket. Seat it firmly and gently close the retaining clips.</p>  <p>Align notches to socket</p> <p>Caution Do not force the DIMM into the socket. Use the notch on one side of the DIMM to determine its orientation in the socket.</p>		

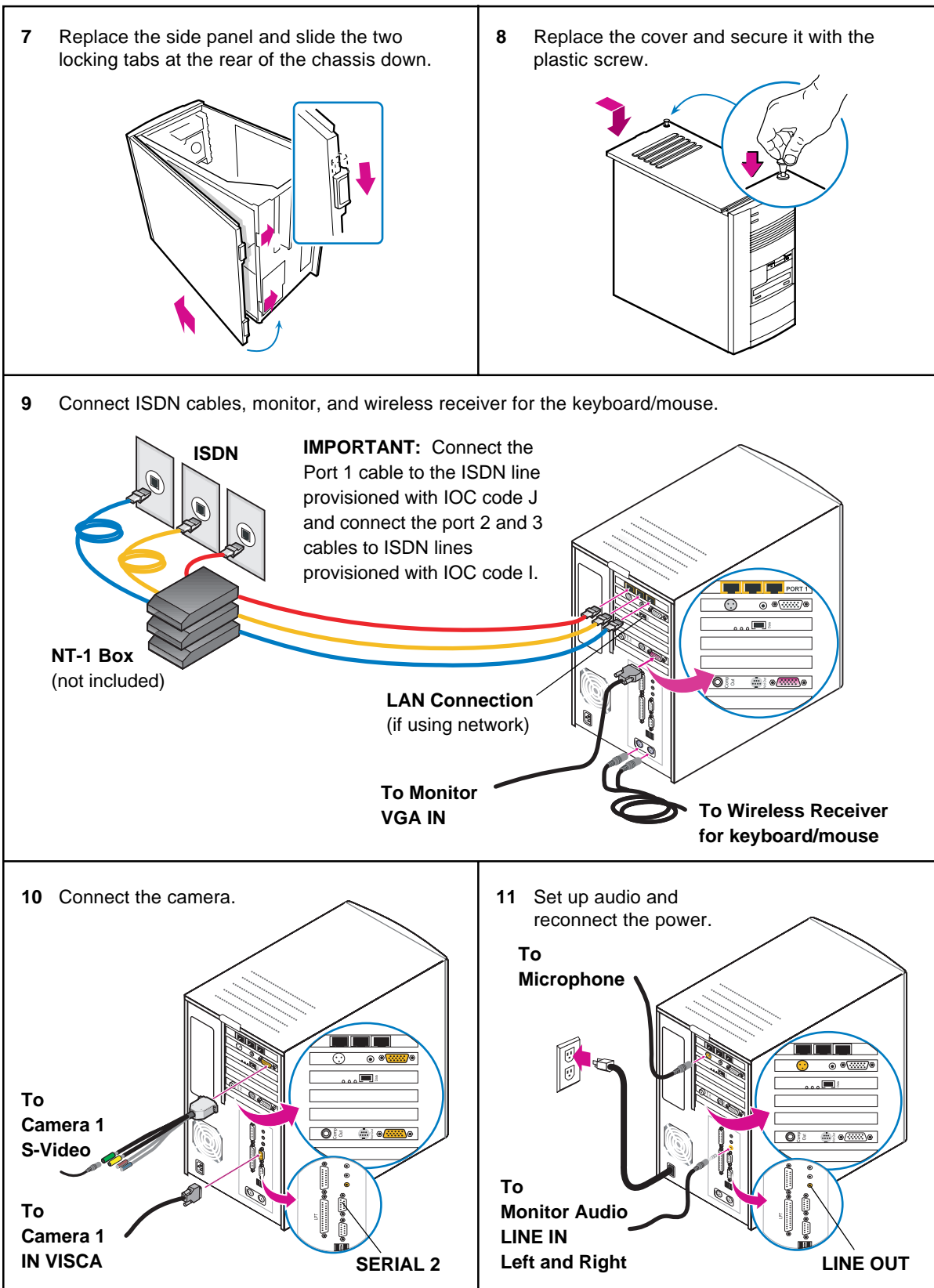

3 Gather ISDN information

To set up your system, you'll need to gather information about your ISDN protocol and switch type as well as ISDN phone numbers. This information is available from your ISDN service provider.

ISDN protocol and Switch Type

- AT&T 5ESS CUSTOM
- AT&T G3 PBX CUSTOM
- NTT INS64 (Japan)
- ETSI (Europe, Australia, Singapore, and other Asian countries)
- NATIONAL ISDN 1 (NI-1)
- NORTEL DMS-100 CUSTOM

ISDN Phone Numbers

(Line 1 provisioned as IOC code J; other lines as IOC code I.)

	LINE	SPID	TYPE (Data/Voice, Data, Voice)
Line 1	#1		
	#2		
Line 2	#3		
	#4		
Line 3	#5		
	#6		

4 Install upgraded Intel TeamStation software

This process will replace the Intel TeamStation System's hard drive contents with Version 4.0a, including Windows NT* and the Intel TeamStation software. The process takes approximately 45 minutes.

For the install process, you will need:

- Intel TeamStation System, Version 4.0a, Restore Diskette (from your upgrade kit)
- Intel TeamStation System, Version 4.0a, Restore CD (from your upgrade kit)
- Microsoft Windows NT Workstation 4.0 CD (part of your original Intel TeamStation System package)
- Windows NT Certificate of Authenticity (located on the cover of the Windows NT manual)

WARNING! This process will erase all of the files on the hard drive, including the Intel TeamStation System's directory of numbers (C:\Program Files\BizVideo\tsdir.ini) and any documents stored on the system with Document Server.

Install the software

- 1 Insert the **Intel TeamStation System, Version 4.0a, Restore Diskette** into the diskette drive and the **Intel TeamStation System, Version 4.0a, Restore CD** into the CD-ROM drive.
- 2 Turn the system OFF.
- 3 Turn the system ON.
- 4 Press **Y** when asked if you want to continue.
- 5 When asked if the memory upgrade has been installed, press **Y** again to continue. (You installed the memory in step 2.)

The Intel TeamStation software files for Version 4.0a are copied to the hard drive.

- 6 When prompted, remove the Intel TeamStation System, Version 4.0a, Restore CD and then insert the **Windows NT Workstation CD** into the CD-ROM drive.
- 7 When prompted, press any key to continue. The system will reboot.
- 8 When prompted to eject the boot floppy, eject the **Intel TeamStation System, Version 4.0a, Restore Diskette**.
- 9 Press any key to install Windows NT.

A blue screen appears that indicates the progress of the Windows NT text-mode setup. When the progress bar reaches 100%, the system will reboot automatically. Windows NT system files are copied and configuration information is created. During this process the system reboots three times.

- 10 When the Windows NT text-mode setup process is complete, you will be prompted to press any key to reboot.

5 Configure Windows NT

After the system reboots, the Windows NT Setup Wizard runs automatically.

- 1 On the first Wizard screen, click **Next**.
- 2 On the Name and Organization screen, enter your name and organization.
- 3 On the Registration screen, enter the Product ID found on the Windows NT manual.
- 4 On the Administration Account screen, enter and confirm a password for the system administrator account.
- 5 Click **Restart** when prompted.
- 6 After the system reboots, a logon box appears. Press **Ctrl+Alt+Del** to log on.
- 7 Log on as “Administrator”.

Set up LAN configuration (optional)

If you'll be using the Intel TeamStation System over a LAN and you wrote down LAN information in step 1, you may want to configure the upgraded system to use the computer name, drive mappings, and other LAN settings from your current (Version 4.0) system.

Add TCP/IP support (optional)

If you want to add TCP/IP, follow the instructions on configuring the Intel TeamStation System for TCP/IP, in the *Intel TeamStation System Administrator's Guide*. If you wrote down TCP/IP settings from your current system in step 1, you may want to use those settings when you add TCP/IP to the upgraded system.

After TCP/IP is installed on the system, change the DNS Host Name to the computer name:

- 1 Right-click **Network Neighborhood** on your desktop and select **Properties**.
- 2 Click the **Protocols** tab.
- 3 Double-click **TCP/IP Protocol**.
- 4 Click the **DNS** tab.
- 5 Change the host name to the computer name.
- 6 Click **OK**.

6 Configure the Intel TeamStation System

- 1 Double-click the **Setup** program icon on the desktop. Follow the instructions on the setup screens.
- 2 When the setup process is complete, click **Restart Windows**.
- 3 After the system reboots, the AdminTools setup wizard runs automatically. Follow the instructions on the wizard screens. The system will reboot automatically when the wizard is complete.
- 4 After the system reboots, the Intel TeamStation software starts automatically. Click **Close** to quit the Intel TeamStation software.
- 5 Double-click **My Computer** on the desktop, then double-click **TeamStation (C:)**. Locate the **I386** folder and drag it to your Recycle Bin.
- 6 Empty the Recycle Bin to free up space on your hard drive.

7 Install Update 1 software

It is crucial that you install the Update 1 software, to ensure that you can take advantage of the most current enhancements to your Intel TeamStation System. We've provided this update on the Restore CD.

The Update 1 file is a self-extracting executable that updates the Intel TeamStation System, Version 4.0a software that you just installed and configured.

- 1 Remove the Windows NT Workstation CD and insert the **Intel TeamStation System, Version 4.0a, Restore CD** into the CD-ROM drive.
- 2 Select Start>Run on the desktop.
- 3 Type the name of the Update 1 file:
D:\TS4AU1NA.EXE (assuming your CD-ROM drive is D:\) and click **OK**.
- 4 Follow the directions on the screen to install Update 1.
- 5 Reboot the system.

8 Verify memory installation

Verify that the system recognizes the additional 32 Mbytes of memory you added in step 2.

- 1 Right-click **My Computer** on the desktop and select **Properties**.
- 2 On the **General** tab, verify that your computer has 97716 KB RAM.

If your computer shows less memory, reseal the new DIMM in the memory socket (see step 2) and verify the amount of memory again.

9 Restore files and applications

Copy backed-up files

Copy the files you backed up in step 1 onto your upgraded system.

- 1 Copy **tsdir.ini** into the directory C:\Program Files\BizVideo.
- 2 Copy any backed-up documents used with Document Server. The default directory is C:\Apache\WWWRoot\Document Server.
- 3 Copy any other backed-up documents where you want them.

Reinstall applications

Reinstall any applications you want to make available to your Intel TeamStation System users.

10 If you use a television set as your display

Skip this step if your system uses a computer monitor.

If you use a television set as your display:

- 1 Install a special video driver (3D RAGE* PRO graphics accelerator, found in ati.inf at C:\Support\Tvdriers).
- 2 Use the Composite video connector (phono or RCA jack) or the S-Video (or S-VHS) connector on the television to connect the video card to the TV.
- 3 Ensure that the display resolution is set to 800 x 600 pixels.

For more detailed video driver instructions, see the Version 4.0a README file. For more information on connecting a television set, see the section on using a television set as your display, in the *Intel TeamStation System Administrator's Guide*.

11 Make a Video Call

Call us to make the first video call with your new system.

- 1 Select Start>Programs>Intel TeamStation System>Intel TeamStation System.
- 2 Click **Video Call**.
- 3 Dial: (503) 712-1086
Be sure to add any prefixes required by your telephone system.

For more information

See the *Intel TeamStation System Administrator's Guide* or your Intel TeamStation software online help.

To get the latest Intel TeamStation software

As part of this upgrade, you installed Update 1. Check our Customer Support site on the World Wide Web periodically to see if there are any further updates. This will allow you to take advantage of additional software enhancements as they become available.

- 1 Point your browser to **<http://support.intel.com>**
- 2 Click the **Video & Conferencing** products hyperlink.
- 3 Click the **Intel TeamStation System** hyperlink.
- 4 Click the **Intel TeamStation System 4.0a** hyperlink.
- 5 Click the **Software & Drivers** hyperlink to download files.



726665-001

* Other product and corporate names may be trademarks of other companies.

Intel Corporation assumes no responsibility for errors or omissions in this guide. Nor does Intel make any commitment to update the information contained herein.

Copyright © 1998 Intel Corporation.