



POLYCOM®

Installing a  
**Collaboration  
System on the  
Premier Cart**



Copyright © 2000-2002: Polycom, Inc.  
Polycom, Inc., 4750 Willow Road, Pleasanton, CA 94588  
www.polycom.com

Polycom and the Polycom logo are registered trademarks of Polycom, Inc.

Velcro is a registered trademark of Velcro USA, Inc.

Bose is a registered trademark of Bose Corporation.

The information contained in this document is subject to change without notice. Polycom assumes no responsibility for technical or editorial errors or omissions that may appear in this document or for the use of this material. Nor does Polycom make any commitment to update the information contained in this document. This document contains proprietary information which is protected by copyright. All rights reserved. No part of this document may be photocopied or reproduced in any form without the prior written consent of Polycom, Inc.

Edition: 3725-50455-001/A

Do you have any suggestions or comments on the documentation you received? If so, please send them by e-mail to [iDesign@polycom.com](mailto:iDesign@polycom.com).

## Before You Start

Make sure you read these important warnings before you start unpacking your cart.

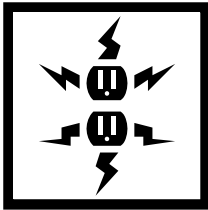
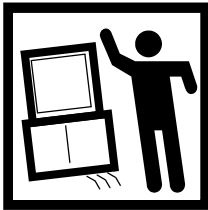

---

### Warnings

---

- Heavy lifting required** - To reduce the chance of personal injury, you need at least two people to perform the lifting required.
  - Install monitor as shown** - Large video monitors are very heavy. Make sure that you mount the monitor as instructed.
  - Avoid tipping** - The Premier Cart has been tested, and IEC 950 and UL-approved, for Polycom-approved 27- and 32-inch monitors (29- and 34-inch monitors for Europe). If you use other monitors, you must ensure that the Premier Cart cannot tip.
  - Monitor Size** - Do not install a monitor larger than 32-inch (34-inch in Europe) on the Premier Cart, or it may tip over.
  - Power cables and polarity** - Use power cables and adapters supplied by Polycom. Others may not have the correct polarity or power ratings and may cause damage.
-



# *Installing a Collaboration System on the Premier Cart*

## **About this Booklet**

This booklet provides instructions for installing an iPower 900 Series Collaboration System on a Premier Cart. You install the computer box on the bottom shelf and up to a 32-inch monitor (34-inch monitor for Europe) on top of the cart. The cart also contains a shelf for a VCR or other optional equipment.

If your iPower 900 Series Collaboration System is a dual-monitor system, see the *iPower 900 Series Collaboration System Administrator's Guide* for complete information about installing the system on the cart when you have two monitors.

This booklet contains the following information:

- Removing the Premier Cart from the pallet ( page 7)
- Installing the computer box (page 9)
- Installing the monitor (page 9)
- Connecting the cables (page 15)
- Moving the Premier Cart (page 20)
- Service and Support (page 20)

To set up the Premier Cart, you will need:

- Phillips screwdriver
- 1/2-inch socket wrench
- Pencil

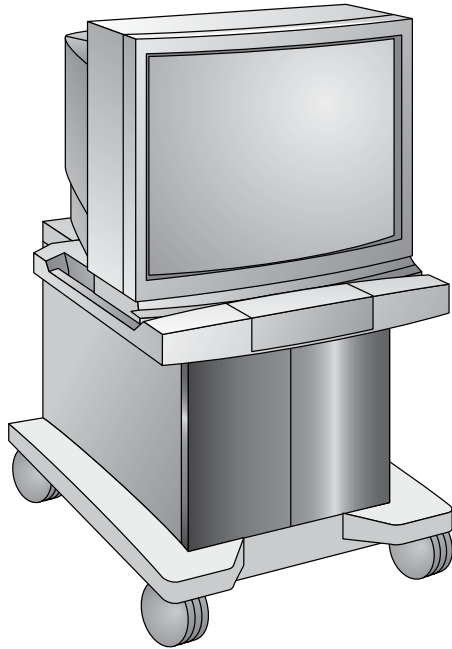

## Removing the Premier Cart from the Pallet

While the Premier Cart is still on the pallet, remove the plastic wrap surrounding it. Be careful not to scratch the cart.

### Attaching the Ramps

The two wooden ramps are shipped with bolts already installed.

To attach the ramps to the pallet:

1. *Slide the two wooden ramps, with bolts attached, **a** out from under the Premier Cart.*
2. *Turn the ramps over so that the bolts are on the bottom.*
3. *Align the bolts with the holes **b** on the edge of the pallet, and insert the bolts into the holes.*

Make sure the ramps can't slip off the pallet.

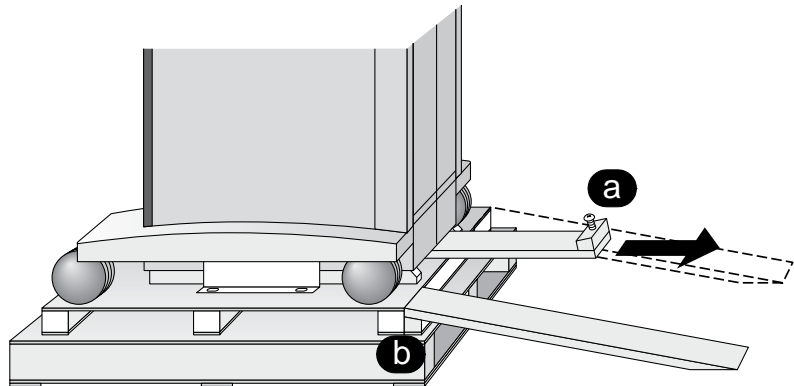

## Removing the Shipping Brackets

To remove the shipping brackets:

1. Use a 1/2-inch socket wrench to unbolt the orange shipping brackets **a** that secure both sides of the Premier Cart to the pallet.
2. Pull the shipping brackets up and then away from the Premier Cart to disengage the bracket tabs from the system's shipping slots **b**.

## Rolling the Premier Cart Off the Pallet and Engaging Its Brakes

To remove the Premier Cart from the pallet:

1. If the brakes located on the front wheels of the cart are locked, lift them up to unlock them.
2. Carefully roll the Premier Cart toward the ramps.
3. Slowly roll the cart off the pallet **c**.
4. To keep the Premier Cart from moving, push down on the brakes.

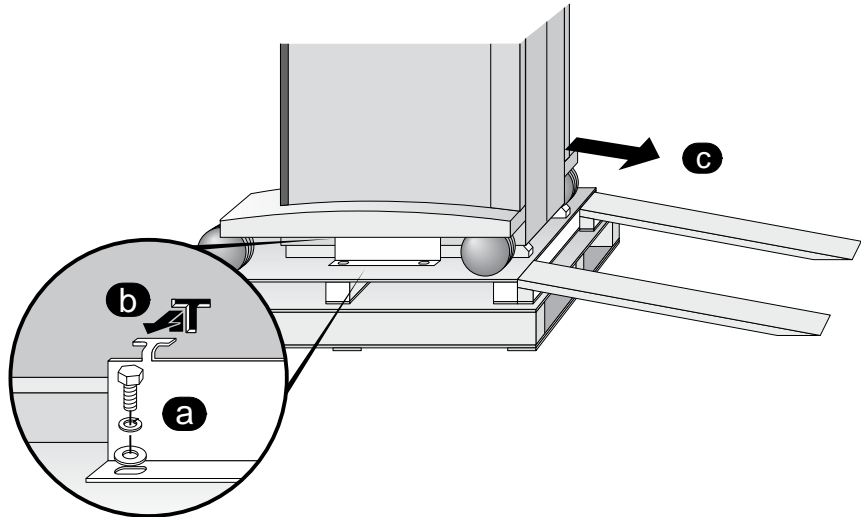

## Installing the Computer Box

The computer box is shipped in its own carton. Once you unpack the computer box, you can install it in the Premier Cart.

To install the computer box on the bottom shelf:

1. *Open the rear door of the Premier Cart.*
2. *Place the computer box on the bottom shelf **a** with the rear of the box facing the back of the cart.*

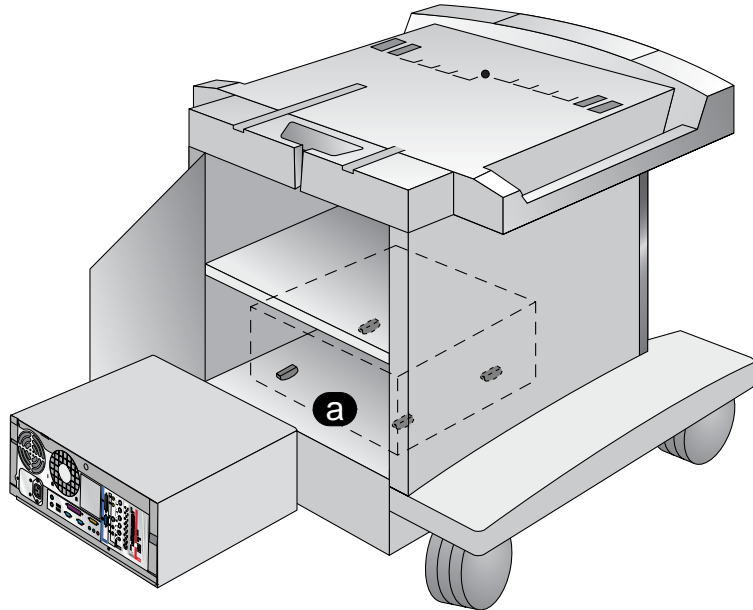

## Installing the Monitor

This section describes how to install the monitor on your Premier Cart. To install the monitor, you need back brackets and Velcro<sup>®</sup> straps, which secure the monitor to the Premier Cart. These are shipped with your cart.

You also need a front bracket, which is shipped in its own box with the collaboration system. The front bracket you receive is the appropriate size for your monitor.

**Note:** These steps are for installing the 27-inch (29-inch in Europe) or 32-inch (34-inch in Europe) monitor that comes standard with the Premier Cart.

## Installing the Front Bracket on the Monitor

To install the front bracket on the cart:

1. Place the bracket on the Premier Cart so that the clamps on the bracket align with the cutouts on the top of the cart **a**.
2. Pull the bracket forward until the hole for the screw on the bracket aligns with the hole in the cart **b**.
3. Use a Phillips screwdriver and the screw provided to secure the bracket to the top of the Premier Cart.

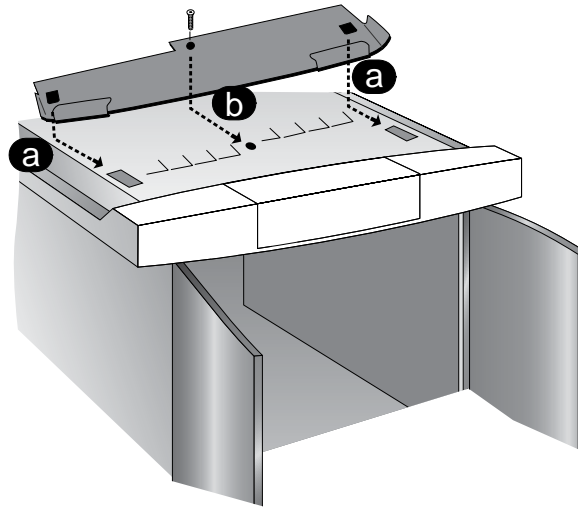

## Installing the Back Brackets for the 27-inch (29-inch in Europe) Monitor

Before you begin, note that you must follow these instructions *exactly* to ensure that the monitor is installed safely.

---

**Warning**

---

If the brackets are not correctly installed, the straps won't hold the monitor securely in place. The monitor could work free of the front bracket, and tip.

---

To install the back brackets for the 27-inch (29-inch in Europe) monitor:

**1. Determine which size monitor you have.**

If you have a 32-inch (34-inch in Europe) monitor, go to the “Installing the Back Brackets for the 32-inch (34-inch in Europe) Monitor” section on page 12.

**2. Position the Velcro straps **a** on top of the cart, as shown, with the loop side of the Velcro facing up.**

You don't need to separate the loop side from the hook side.

**3. Place the brackets on top of the straps, aligning the holes in the brackets with the holes in the Velcro straps and the holes in the grooves **b** on the cart. Make sure that the loose ends of the straps extend beyond the rear of the Premier Cart.**

The two holes in the brackets must be aligned with the 5th and 7th holes counting from the back of the cart (the brackets will cover the 6th hole).

**4. Insert the screws through the brackets and straps and into the Premier Cart. Tighten the screws.**

To continue the installation of your monitor, go to page 13, “Positioning the Monitor on the Premier Cart.”

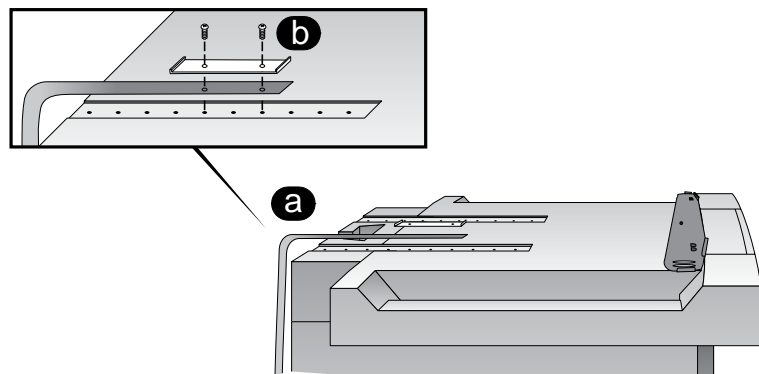

## Installing the Back Brackets for the 32-inch (34-inch in Europe) Monitor

Before you begin, note that you must follow these instructions *exactly* to ensure that the monitor is installed safely.

---

### Warning

---

If the brackets are not correctly installed, the straps won't hold the monitor securely in place. The monitor could work free of the front bracket, and tip.

---

To install the back brackets for the 32-inch (34-inch in Europe) monitor:

1. **Position the Velcro straps **a** on top of the cart, as shown, with the loop side of the Velcro facing up.**

You don't need to separate the loop side from the hook side.

2. **Place the brackets on top of the straps, aligning the holes in the brackets with the holes in the Velcro straps and the holes in the grooves **b** on the cart. Make sure that the loose ends of the straps extend beyond the rear of the Premier Cart.**

The two holes in the brackets must be aligned with the 3rd and 5th holes counting from the back of the cart (the brackets will cover the 4th hole).

3. **Insert the screws through the brackets and straps and into the Premier Cart. Tighten the screws.**

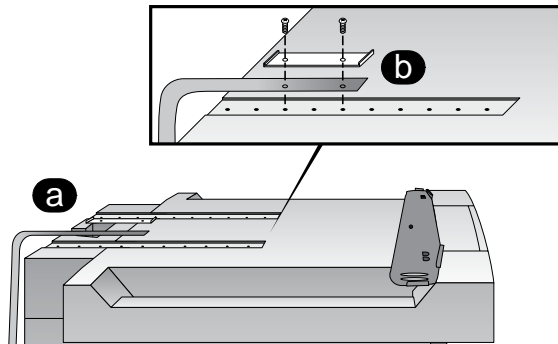

## Positioning the Monitor on the Premier Cart

When you have completed the installation of the brackets on your Premier Cart, you are ready to install the monitor.

**Note:** Do not install a monitor larger than 32-inches (34-inches in Europe) on the Premier Cart. Also, because large monitors are very heavy, be sure to mount the monitor as instructed.

To install the monitor:

- 1. Push down on the brakes located on the front wheels of the Premier Cart to prevent the cart from moving.**
- 2. Gently position the monitor on the Premier Cart.**
- 3. Carefully move the monitor forward into the bracket on the front of the cart until it is secure.**

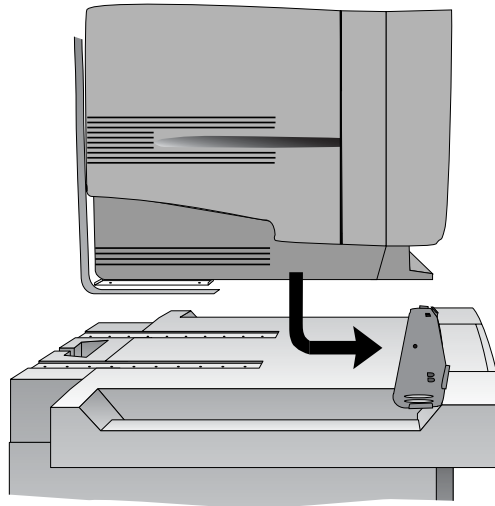

## Sticking the Velcro Straps onto the Monitor

The Velcro straps help secure your monitor to the cart.

To stick the Velcro straps onto the monitor:

1. *Make sure that the hook and loop sides of the Velcro are stuck together and are aligned at the top of the strap.*
2. *Pull up on one of the Velcro straps until it is taut. Make sure that the strap fits securely over the bottom corner of the monitor.*
3. *With a pencil, mark the back of your monitor to indicate the top position of the strap.*
4. *Remove the backing **a** from the hook side of the Velcro strap. This exposes the adhesive that will attach the strap to the monitor.*
5. *Stick the strap vertically to the back of the monitor **b** using the pencil mark as a guide.*
6. *Repeat steps 1 through 5 to attach the second strap.*

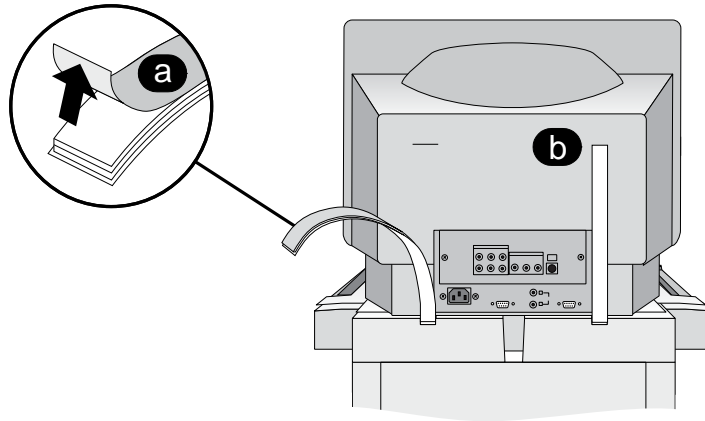

## Connecting the Cables

Now that the monitor is attached to the cart, you must place the camera on the monitor and connect it. See the document that you received with your camera for instructions on how to attach the camera to the monitor.



Once you have set up your camera, refer to this section for information on connecting audio and power cables to the Premier Cart.

**Note:** If your collaboration system was shipped with two monitors, see the *iPower 900 Series Collaboration System Administrator's Guide* for instructions on installing cables with dual-monitors systems.

## Connecting the Audio Cables

The Premier Cart contains a Bose® speaker with a pre-installed audio power cable.

To connect the audio cables when you have an iPower 80 camera:

- 1. At the back of the collaboration system, plug the orange end of the audio output cable into the orange LINE OUT  connector  on the computer box.**

The audio output cable came packaged with the iPower 970 or iPower 960 Collaboration System.

- 2. Plug the white end of the audio output cable into the single end of the black Y-adaptor cable .**

The black Y-adaptor cable came packaged with the iPower 80 camera.

3. **Plug another end of the black Y-adapter cable into the audio cable from the Bose speaker **c**.**

The audio cable from the Bose speaker is located on the inside of the Premier Cart.

4. **Plug the remaining end of the black Y-adapter cable into the end of the audio cable that has the ferrite bead **d**.**

The audio cable with the ferrite bead came packaged with the iPower 80 camera.

5. **Plug the other end of the audio cable into the white audio input connector **e** on the back of the iPower 80 camera.**

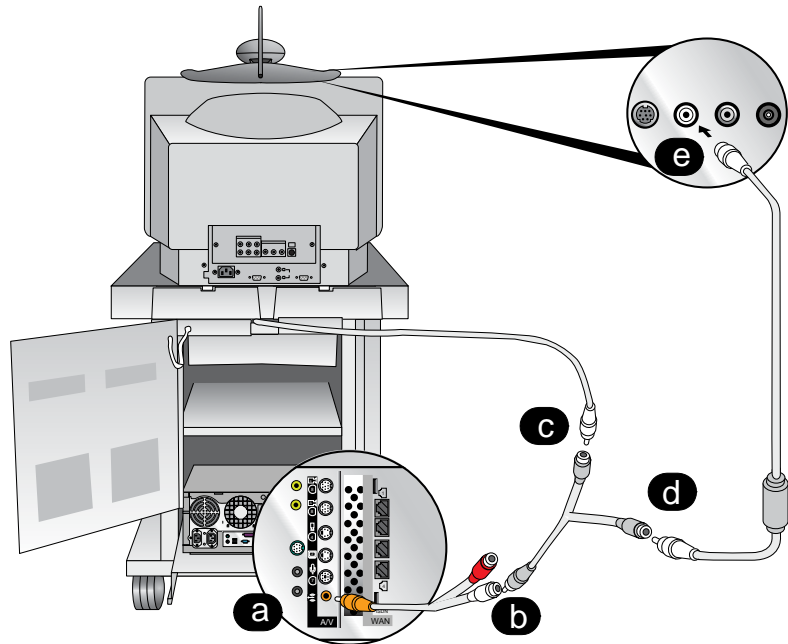

To connect the audio cables when you have an iPower 70 camera:

1. **At the back of the collaboration system, plug the orange end of the audio output cable into the orange LINE OUT connector **a** on the computer box.**

The audio output cable came packaged with the iPower 970 or iPower 960 Collaboration System.

2. **Plug the white end of the audio output cable into the audio cable from the Bose speaker **b**.**

The audio cable from the Bose speaker is located on the inside of the Premier Cart.

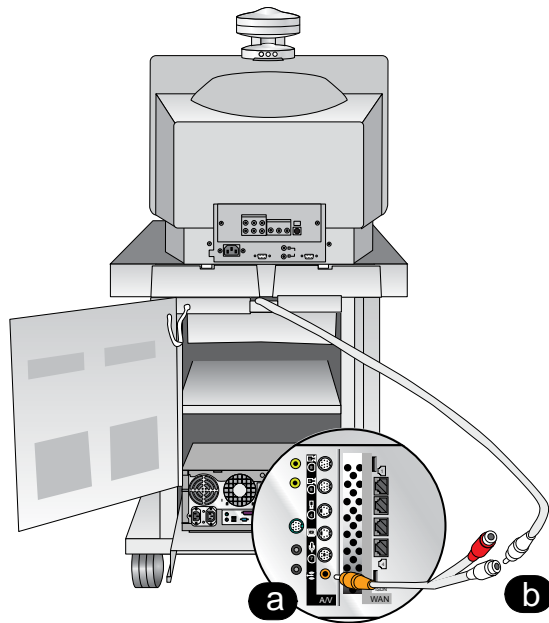

## Connecting the Monitor's Power Cable

The monitor's power cable connects to the Premier Cart with a power adapter cable. This power adapter cable is shipped with the cart.

To plug in the monitor's power cable:

1. **Plug the power cable into the power connector on the back of the monitor **a**.**
2. **Run the power cable from the monitor down through the center channel on the rear of the cart.**
3. **Plug the power cable into the power adapter cable **b** that was shipped with your cart.**
4. **Plug the power adapter cable into the power strip **c** inside the Premier Cart.**

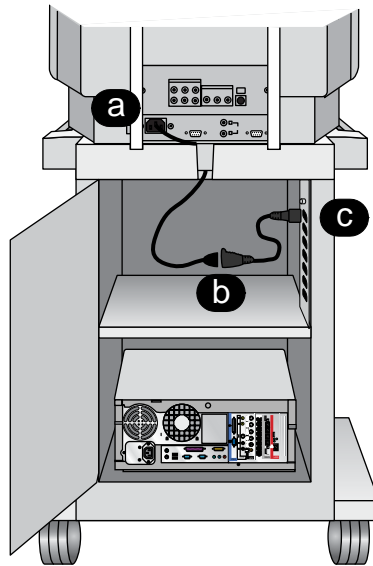

## Connecting the Computer Box Power Cable

To connect the computer box power cable:

1. **Plug the power cable that was shipped with your cart into the power receptacle **a** on the computer box.**
2. **Plug the other end of the power cable into the power strip **b** inside the Premier Cart.**

You use the power cable that was supplied with the Country Kit to connect the power strip on the Premier Cart to a wall outlet.

To connect the power strip to a wall outlet:

1. **Plug the power cable that was shipped with your Country Kit **c** into the power strip.**
2. **Plug the other end of the Country Kit power cable into a wall outlet **d**.**

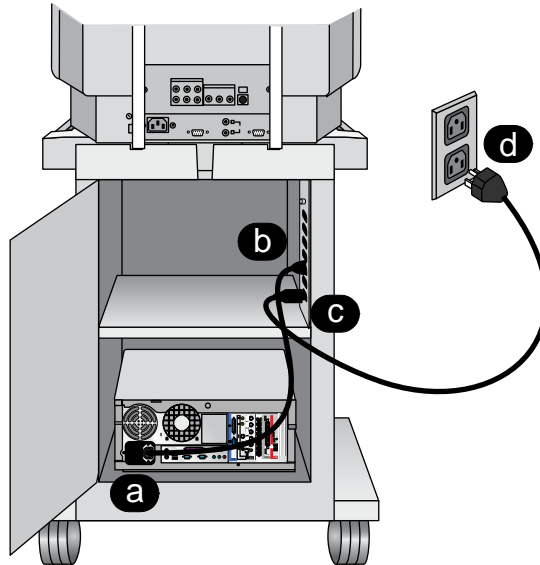

## Moving the Premier Cart

When you move the Premier Cart:

- Unplug all cables from wall outlets and network connectors before you roll the cart.
- Do not push the Premier Cart on any incline that is greater than 10 degrees.
- Push the cart from its side using the indented handles provided for your convenience.

The Premier Cart can fit through a doorway that is at least 28 inches (71 centimeters) wide if you push it from its side.

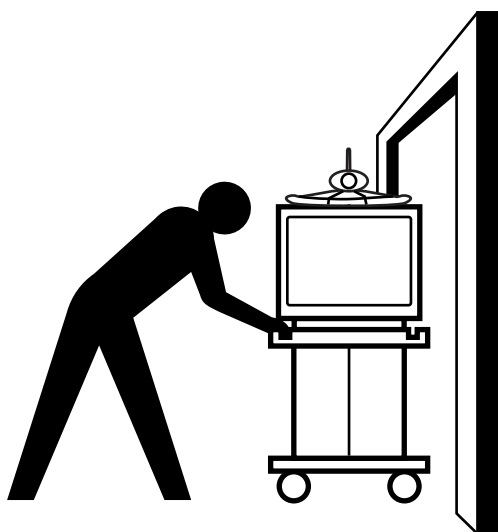

## Service and Support

For support or service, please contact your Polycom service provider or call Polycom Technical Support. You can find phone numbers for Technical Support in your area at the Polycom web site, [www.polycom.com](http://www.polycom.com).