



▶ Polycom® RMX® 4000
Hardware Guide

Trademark Information

Polycom®, the Polycom “Triangles” logo, and the names and marks associated with Polycom’s products are trademarks and/or service marks of Polycom, Inc., and are registered and/or common-law marks in the United States and various other countries.

All other trademarks are the property of their respective owners.

Patent Information

The accompanying product is protected by one or more U.S. and foreign patents and/or pending patent applications held by Polycom, Inc.

© 2011 Polycom, Inc. All rights reserved.

Polycom, Inc.
4750 Willow Road
Pleasanton, CA 94588-2708
USA

No part of this document may be reproduced or transmitted in any form or by any means, electronic or mechanical, for any purpose, without the express written permission of Polycom, Inc. Under the law, reproducing includes translating into another language or format.

As between the parties, Polycom, Inc., retains title to and ownership of all proprietary rights with respect to the software contained within its products. The software is protected by United States copyright laws and international treaty provision. Therefore, you must treat the software like any other copyrighted material (e.g., a book or sound recording).

Every effort has been made to ensure that the information in this manual is accurate. Polycom, Inc., is not responsible for printing or clerical errors. Information in this document is subject to change without notice.

Table of Contents

Hardware Description	1-1
Main Features	1-1
RMX 4000 Specifications	1-2
RMX 4000 System Capacities	1-3
Conferencing Capacities	1-3
Resource Capacities per Card Assembly	1-4
MPMx Card	1-4
MPM+ Card	1-4
Resource Capacities per Card Type (MPM+ and MPMx)	1-5
Safety Requirements	1-6
Site Safety Requirements	1-6
General Installation Precautions	1-6
Rack Mount Safety Precautions	1-7
Installing the RMX 4000	1-7
Unpacking the RMX 4000	1-7
Installing the RMX in a Rack or as a Standalone	1-9
Standalone RMX 4000 Installation	1-9
Rack Mount Preparations	1-9
Placing the RMX 4000 in a 19" Rack	1-10
Placing the RMX 4000 in a 23" Rack	1-11
Reverse Mounting the RMX 4000 in a Rack	1-12
Connecting the RMX 4000 to Power Sources	1-12
Connecting the RMX 4000 to AC Power	1-13
Connecting the RMX 4000 to -48DC SELV Power	1-14
Types of DC Circuit Breakers installed on the RMX 4000	1-15
Connecting Cables to the RMX 4000	1-15
First-time Power-up	1-16
RMX 4000 Components	1-17
RMX 4000 Front Panel	1-17
MPM+ and MPMx Media Cards	1-19
RMX 4000 Rear Panel	1-20
RTM-IP 4000	1-21
RTM ISDN	1-22
ISDN/PSTN Clock Source	1-22
RTM LAN	1-23
AC Power Entry Module (PEM)	1-23
DC Power Rail Module	1-23
Component Slot Allocation	1-24
RMX 4000 LEDs	1-25
RMX 4000 Front Panel LEDs	1-25
RMX 4000 Rear Panel LEDs	1-28
RTM-IP 4000	1-28
RTM LAN	1-29

RTM ISDN	1-29
DC Power Rail LEDs	1-30
Using the Modified PMC Compatible Ejector Lever	2-2
Replacing the CNTL 4000 Module	2-2
Replacing an AC Power Supply Module	2-3
Replacing an AC Power Entry Module (PEM)	2-4
Replacing a DC Power Rail Module (PRM)	2-5
Replacing the Fan Drawer	2-7
Inserting an Air Filter (Optional) in the Fan Drawer	2-8
Removing an Faulty MPM+/MPMx Card	2-9
Removing the MPM+/MPMx Card from the MCU	2-9
Installing or Replacing MPM+/MPMx Card on the RMX 4000	2-10
Replacing the RTM ISDN Card	2-11
Replacing the RTM-IP 4000	2-12
Replacing the RTM LAN	2-13
Replacing the Fabric Switch Module (FSM 4000)	2-14
Appendix A - Pin Assignment	A-1
PRI Port Assignment	A-1

Hardware Description

This Hardware Guide provides information on the RMX 4000 and its components. This system utilizes a modular “universal slot” platform, whose components are designed for high performance, capacity and reliance.

Main Features

The Polycom RMX 4000 offers the following features:

- Linux® based
- Chassis based on the ATCA standard
- Built-in redundancy, hot swappable parts
- Physical separation between management and signaling networks, with high speed switching fabric on the media boards increasing system bandwidth
- Support for standard network interfaces (IP, ISDN and LAN) and large number of ports.
- H.323, SIP video, PSTN and ISDN
- New hardware technologies
- High availability, redundancy, on-line upgrading and dynamic resource allocation
- Easy integration of conference elements into external network management
- Enhanced Continuous Presence (multi-image video)
- IVR (Interactive Voice Response) module
- Resilient multipoint conferencing - Polycom Lost Packet Recovery (LPR)

RMX 4000 Specifications

Table 1-1 Polycom RMX 4000 Specifications

Physical	
Height	6U (26.56 cm.)
Width	19" (48.26 cm.)
Depth	15.74" (40 cm.)
Weight	Up to 40 Kg (88 lbs).
Media Protocols	
Audio	G.711a/u, G.722, G.722.1C, G.722.1, G.723.1, G.719, G.728, G.729A, and Polycom Siren™ 14 and Siren 22 (in mono or stereo)
Video	H.261, H.263 (H.263++), H.264 High Profile
Network Interfaces	
IP, ISDN, PSTN and LAN	IP H.323, SIP, PSTN, VoIP voice, LAN and ISDN (H.320).
Power Supply	
AC Input/ Range, BTU	Voltage range:100-240 VAC ±10%, 15 AMP, 50/60 Hz. Maximum BTU output per hour: 5120.
DC Input/Range, BTU	Voltage range:-40.5-60 V DC SELV, with circuit breaker. Maximum BTU output per hour: 5120.
Power Consumption	
AC Maximum Power consumption	1500 Watts
DC Maximum Power consumption	1500 Watts
Environment	
Operating temperature	10° to 40°C (50° to 104°F).
Storage temperature	-40° to 70°C (40° to 158°F).
Relative humidity	15% to 90% noncondensing.
Operating altitude	60 m (200 ft.) below sea level, up to 3,000 m (10,000 ft.).
Operating ESD	4kV.

RMX 4000 System Capacities

Conferencing Capacities

The following table summarizes the different system capacities.

Table 1-2 System Functions and Capacities RMX 4000

System Functions	MPM+ Mode	MPMx Mode
Maximum number of Video participants in a conference	160	180
Maximum number of PSTN participants in a conference	400	400
Maximum number of VOIP participants in a conference	800	720
Maximum number of Audio calls per second	5	5
Maximum number of Video calls per second	2	2
Maximum number of Conferences	800	800
Maximum number of Meeting Rooms	2000	2000
Maximum number of Entry Queues	80	80
Maximum number of Profiles	80	80
Maximum number of Conference Templates	200	200
Maximum number of SIP Factories	80	80
Maximum number of IP Services	4	4
Maximum number of ISDN Services	2	2
Maximum number of IVR Services	80	80
Maximum number of Recording Links	20 (default)	20 (default)
Maximum number of IVR Video Slides	150	150
Maximum number of Log Files (1Mb max.)	8000	8000
Maximum number of CDR Files	4000	4000
Maximum number of Fault Files	1000	1000
Number of Participant alerts	Unlimited	Unlimited
Maximum number of concurrent RMX Web Client connections to the MCU	20	20
Maximum number Address Book entries	4000	4000
Maximum number of Users	100	100
Maximum number of Gateway Profiles	80	80
Maximum number of Reservations (internal Scheduler)	4000	4000

Resource Capacities per Card Assembly

MPMx Card

Two *MPMx* card assemblies are available: *MPMx -S* (Single) and *MPMx-D* (Double) each offer different resource capacities, as summarized in Table 1-3:

Table 1-3 *MPMx – Resource Capacity per Card per Resolution (CP Mode)*

Resource Type	MPMx - S	MPMx - D
Voice	180	360
H.263 CIF	30	60
H.263 4CIF15	15	30
H.264 CIF	45	90
SD H.264	30	60
HD720p30	15	30
HD720p60/ HD1080p30	8	15 (Symmetrical)

MPM+ Card

Three *MPM+* card assemblies are available: *MPM+ 80*, *MPM+ 40* and *MPM+ 20* offering various resource capacities for CP conferences, as summarized in Table 1-4:

Table 1-4 *MPM+ Card Assemblies and Resource Capacities (CP Mode)*

Card Type	Resources					
	Voice	CIF	SD @30fps	HD720p @30fps	HD720p @60fps	HD1080p @30fps
MPM+ 80	400	80	30	20	10	10
MPM+ 40	200	40	15	10	5	5
MPM+ 20	100	20	7	5	2	2

Resource Capacities per Card Type (MPM+ and MPMx)

Table 1-5 summarizes resource capacities of the various cards that can be installed in an RMX per resolution in CP conferencing mode.

Table 1-5 MPMx and MPM+ Resource Capacity per Resolution in CP

Resource Type	Maximum Possible Resources Per Card	
	MPM+	MPMx
<i>HD720p60/HD1080p30 Symmetric</i>	Not Applicable	15
<i>HD720p60/HD1080p30 Asymmetric</i>	10	15
<i>HD720p30/ SD 60</i>	20	30
<i>SD 30 (H.264)/ 4CIF 60</i>	30	60
<i>4CIF (H.263)</i>	30	30
<i>CIF (H.264)</i>	80	90
<i>CIF (H.263)</i>	80	60
<i>Audio only (VoIP)</i>	400	360
<i>ISDN</i>	7 E1 or 9 T1 (per RTM ISDN card)	

Table 1-6 summarizes resource capacities of the various cards that can be installed in an RMX per line rate in VSW conferencing mode.

Table 1-6 MPMx and MPM+ Resource Capacity per Line Rate in VSW

Resource Type	Maximum Possible Resources Per Card	
	MPM+	MPMx
<i>VSW 2Mbps</i>	80	72
<i>VSW 4Mbps</i>	40	63
<i>VSW 6Mbps</i>	20	54
<i>ISDN</i>	7 E1 or 9 T1 (per RTM ISDN card)	

Safety Requirements

This section describes the requirements your site must meet for safe installation and operation of the system.

Site Safety Requirements

For your protection, please read these safety instructions completely before operating the equipment.

- Look carefully for potential hazards in your work area: moist floors, ungrounded power cables, frayed power cords, missing safety grounds and so forth.
- Locate the main circuit breaker within the room.
- Locate the emergency power **OFF** switch within the room.
- Never assume that power is disconnected from a circuit.
- Use only the power cords supplied with the system.
- Each power cord should only be connected to a power outlet that has a protective ground contact.
- Ensure that power cords are easily accessible from the back of the system at all times.
- Place the equipment in a well-ventilated area where the vents are free from obstruction.
- Do not place heavy objects directly on top of the RMX 4000 unit.
- Do not use liquids around your equipment.
- Keep the area around the RMX 4000 clean and free of clutter.
- Decide on a suitable location for the equipment rack that will hold the RMX 4000 unit. It should be situated in a clean, dust-free area that is well ventilated. Avoid areas where heat, electrical noise and electromagnetic fields are generated. You will also need it placed near a grounded power outlet.

General Installation Precautions



Attention:

The RMX 4000 can weigh up to 40 kg when all slots are occupied. Two people are required to lift the MCU out of the box and also when installing it in a rack.

- Use a regulating uninterruptable power supply (UPS) to protect the RMX 4000 from power surges and voltage spikes, to keep your MCU operating in case of a power failure. The RMX 4000 requires either two (DC) or three (AC) power supply cables, each connected to a power supply.
- Allow the power supply units to cool before touching them.
- When handling electronic components, standard anti-static precautions must be observed:
 - Wear a grounding strap
 - Handle cards by their edges only and do not touch their components or connector pins
 - Keep components in anti-static bags, when not installed in the RMX 4000

Rack Mount Safety Precautions

The following precautions should be followed when installing the RMX 4000 on a rack:

- The RMX 4000 has a height of 6U. Ensure this space is available on the rack.
- Ensure that the leveling jacks on the bottom of the rack are fully extended to the floor with the full weight of the rack resting on them.
- In a single rack installation, stabilizers should be attached to the rack.
- In multiple rack installations, the racks should be coupled together.
- Always make sure the rack is stable before extending a component from the rack.
- You should extend only one component at a time - extending two or more simultaneously may cause the rack to become unstable.
- Before you install the rails, determine the placement of each component in the rack.
- Install the heaviest components on the bottom of the rack first, and then work up.
- Always keep the rack's trays and card's slots closed when not servicing, to maintain proper cooling.

Installing the RMX 4000

The following procedures have to be performed to install the RMX 4000 in your site:

- Unpacking the RMX 4000
- Installing the RMX in a rack or as a standalone
- Connecting the RMX 4000 to the power source
- Connecting the network (LAN, IP and ISDN) cables to the RMX

Unpacking the RMX 4000

To unpack and lift the RMX 4000:

- 1 When you receive the RMX 4000 packing case, inspect the equipment for damage and verify that the components match the packing slip.
- 2 The RMX 4000 is shipped in a packing case with Stratocell® packaging, and the top cover must be unlocked and lifted where the RMX is placed on the inside of an anti-static plastic bag.
- 3 Open the top cover of the packing case.

Two boxes are placed on the top Stratocell®, labelled:

- *Installation Accessories*. This kit contains the power cables and a USB Key.
- *Rack Installation Accessories*. This kit contains the accessories for the 19" & 23" racks as follows:

Table 1-7 19" & 23" Rack Installation Accessories Package

Item ID	Description	Quantity
MEC2474A-L0	Chassis runner for rack installation on the RMX 4000. 19" & 23" racks both require that these runners be installed on the rack.	2

Table 1-7 19" & 23" Rack Installation Accessories Package

Item ID	Description	Quantity
MEC2475A-L0	23" bracket to be fitted to the front of the RMX 4000.	2

Make sure that boxes contain all the required parts.

- 4 Remove the boxes and top Stratocell®.

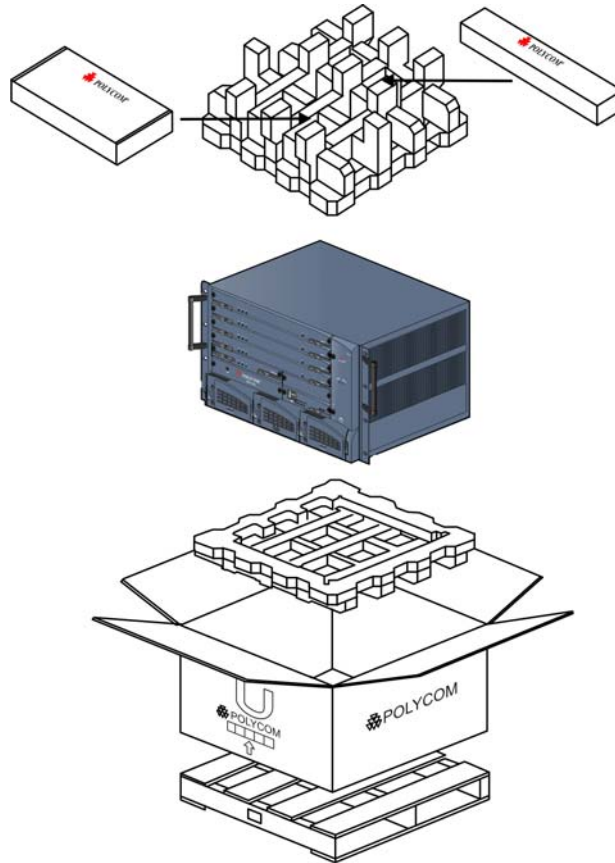

- 5 Holding the handle on each side, lift the RMX 4000 from the box, and place it on a flat surface or install it in a rack. Remove any packaging material prior to positioning the RMX 4000.



Attention:
Two people are required to lift the MCU out of the box and when installing it in a rack.

Installing the RMX in a Rack or as a Standalone

Either place the RMX 4000 on a hard, flat surface such as a desktop or mount it on a 19" /23" rack.

Standalone RMX 4000 Installation

- >> Place the RMX 4000 on a flat surface or desktop.
The RMX 4000 must rest on the four feet at the base of the MCU and must be shifted or moved into position using the two handles attached to the front.

Rack Mount Preparations

- Optional - Depending on the rack installed in your site, you may need to remove the handles if they are attached to the RMX 4000. Unscrew the handles from the chassis as shown in Figure 1-1, "Optional - Feet and handle removal".
- Optional - If the opening in the rack that is allocated to the RMX 4000 is exactly 6U, the feet must be removed from the RMX 4000 to install it in the rack. Unscrew the feet from the chassis as shown in Figure 1-1, "Optional - Feet and handle removal".

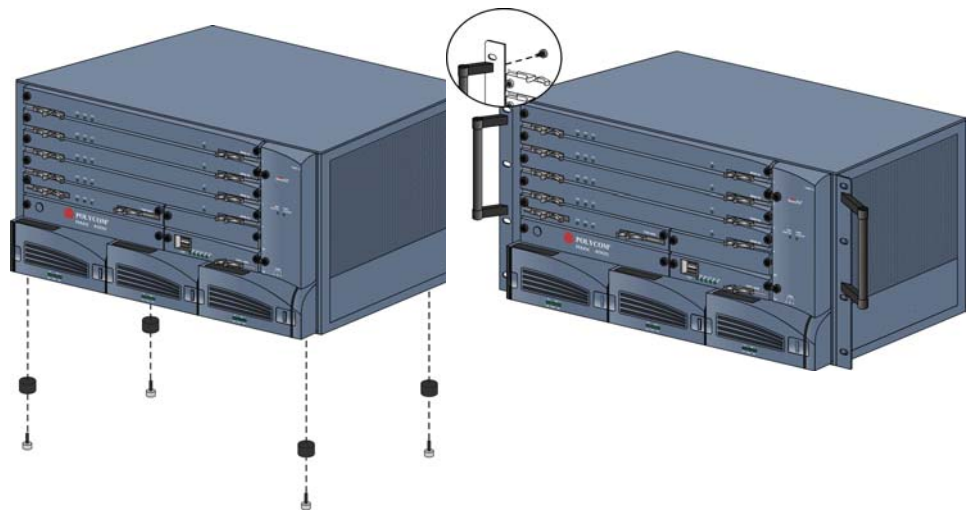

Figure 1-1 Optional - Feet and handle removal

Placing the RMX 4000 in a 19" Rack

- 1 When the RMX is to be rack mounted chassis runners must be installed on the rack as shown in Figure 1-2. Two chassis runners are included in the *Rack Installation Accessories* kit and are attached facing inward from the outside of the 19"/23" rack mount.

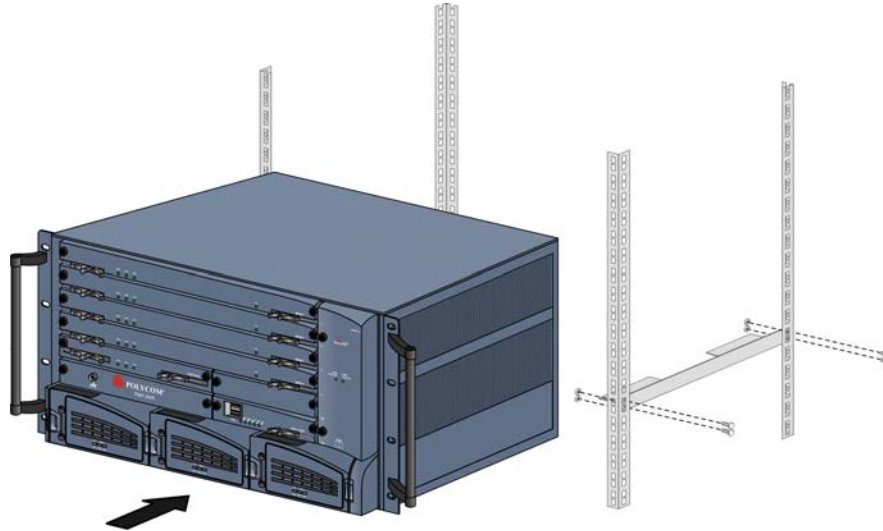

Figure 1-2 Installing chassis runners and RMX in a rack

- 2 Mount the RMX on top of the rack brackets using the blades or placing it on a rack mount shelf with runners.
- 3 Fasten the RMX to the rack with 8 screws into the holes provided on the RMX's front as shown in Figure 1-3.

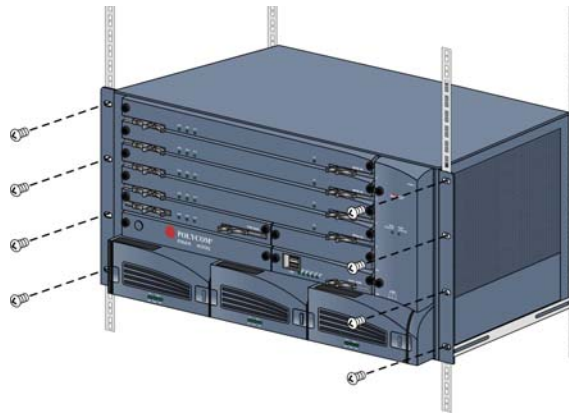

Figure 1-3 RMX 4000 Rack Mount



Rack mounting screws must be supplied by the rack's manufacturer.

The airflow of the RMX 4000 is from right to left. Be sure that the areas on the left and right side of the system are clear for proper ventilation.



When the unit is installed on a rack, the rack must be properly grounded to the central office ground. The rack must be grounded with two-hole compression-type connectors using copper conductors (tinned or untinned). Wire, bus bar or braided strap connectors are acceptable.

Placing the RMX 4000 in a 23" Rack

- 1 Mounting the RMX 4000 on a 23" rack requires that first the handles and then the 19" brackets be removed from the MCU. This is shown in Figure 1-4.

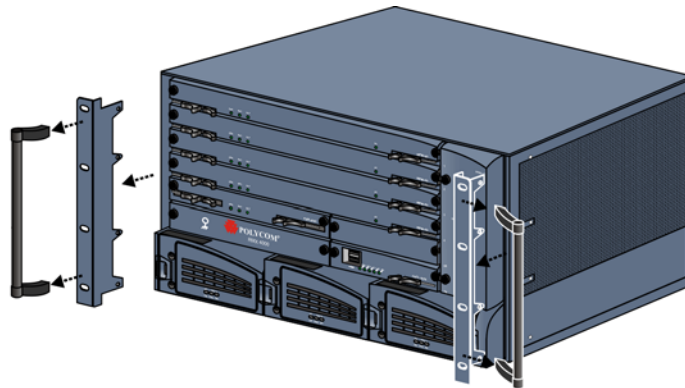

Figure 1-4 Removing and attaching 19" and 23" brackets

- 2 After removal, attach the 23" brackets as provided in the *Rack Installation Accessories kit*, and re-install the handles to the 23" brackets. This is shown in Figure 1-5.

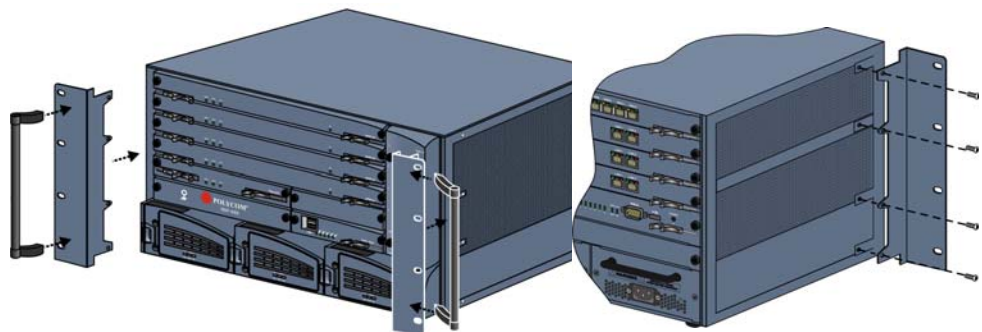

Figure 1-5 Installing the handles and brackets & detailed rear view of 23" bracket attachment

- 3 Mount the RMX on top of the rack brackets using the blades or place it on a rack mount shelf with chassis runners.
- 4 Fasten the RMX to the rack with 8 screws into the holes provided on the RMX's front as shown in Figure 1-3.

The airflow of the RMX 4000 is from right to left. Be sure that the areas on the left and right side of the system are clear for proper ventilation.



When the unit is installed on a rack, the rack must be properly grounded to the central office ground. The rack must be grounded with two-hole compression-type connectors using copper conductors (tinned or untinned). Wire, bus bar or braided strap connectors are acceptable.

Reverse Mounting the RMX 4000 in a Rack

It is possible to reverse mount the RMX 4000 in a rack using 19" or 23" brackets.

To reverse mount the RMX 4000 on a 19" rack:

- 1 Remove the handles and brackets from the front of the RMX.

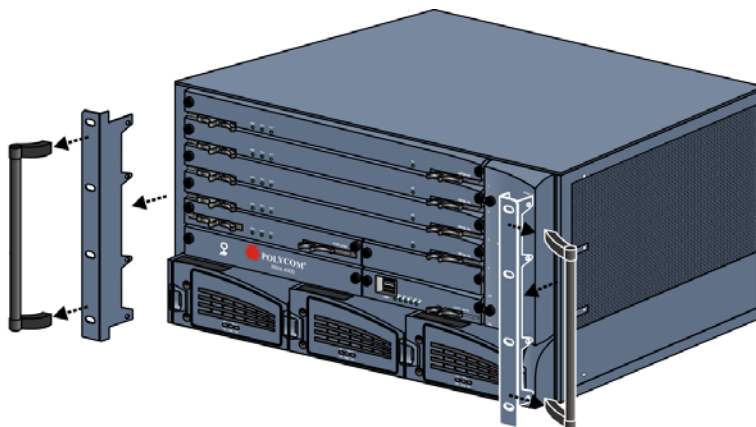

- 2 Attach the brackets to the rear of the RMX.
- 3 Place the RMX in a rack and tighten the 8 screws securing the RMX to the rack.

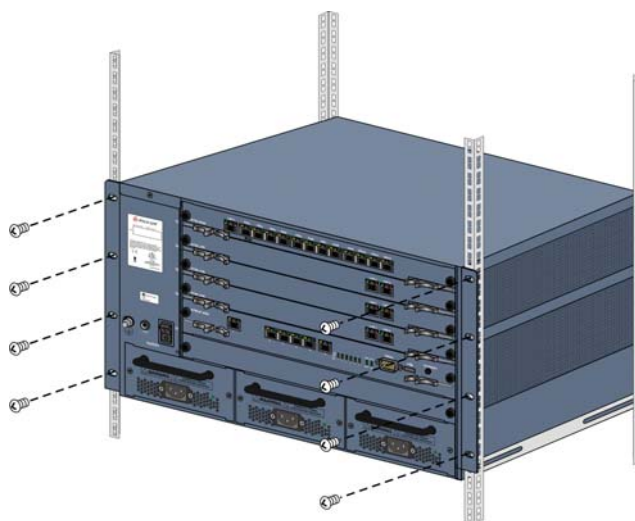

Connecting the RMX 4000 to Power Sources

You can connect either an AC Inlet or to DC power according to the power system required at your site:

- For systems with AC Power, up to three power supplies can be installed with one being redundant (n+1).

- For systems with DC Power, up to two power supplies can be installed with one being redundant (n+1), and each power supply has a built in circuit breaker. With DC power, slot 10 (the center slot) must remain unoccupied.

Follow the steps appropriate specified below for your power system.

The following restrictions apply to the conductors and connectors that may be used to ground the unit when rack mounted:

- When using bare conductors, they must be coated with an appropriate antioxidant compound before crimp connections are made. Tinned, solder-plated or silver-plated connectors do not have to be prepared in this manner.
- The same bolt assemblies should not secure multiple connectors.
- Listed fastening hardware must be compatible with the materials being joined and must be preclude loosening, deterioration and electrochemical corrosion of the hardware and joint materials.

Connecting the RMX 4000 to AC Power



- Do not connect the green or green-yellow wire to the system single-point ground screw.
- Customers are required to only use AC power cables supplied by Polycom.
- The size of the protective earthing conductor should be a minimum of 10 AWG.
- All three outlets intended for connection of the three power cords must be protected with an external overcurrent protection device either in building or in the rack with the rating not higher than 20 Amp.
- Do not use an Extension cords with any of the cables.

- 1 Make sure that the power button is switched OFF on the RMX 4000.

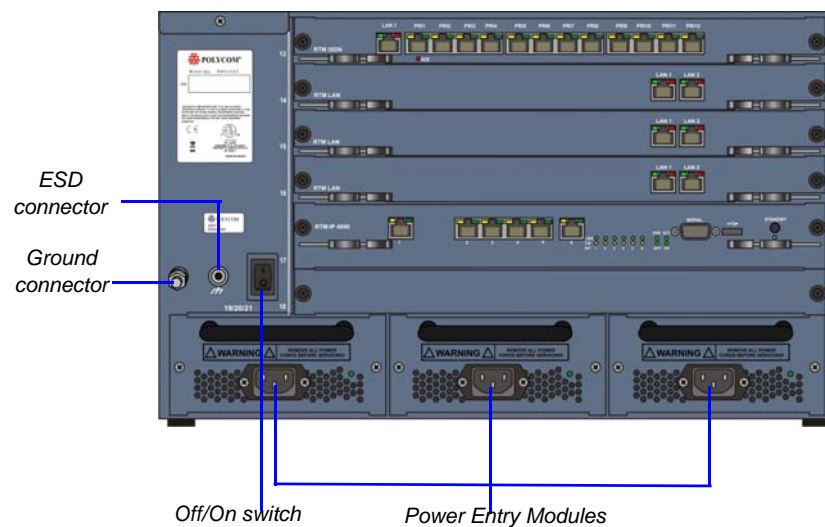

- 2 Insert the power cables into the power connectors on the rear panel of the RMX 4000.

Connecting the RMX 4000 to -48DC SELV Power

- 1 On the DC Power Rail Modules (PRM's), set the two circuit breakers to OFF. For more information on circuit breaker types, see "*Types of DC Circuit Breakers installed on the RMX 4000*" on page 1-15.
- 2 Ensure that the cables from the Main that supplies electricity to the DC power units are OFF or disconnected.
- 3 Remove the transparent plastic caps on the terminal block.
- 4 Using the two wires of an 10 AWG cable running from the DC power distribution unit, connect the black wire into the -48 VDC terminal block and the red wire to the RTN terminal block.



- A 10 AWG cable must be used to connect the mains with the RMX 4000 DC Power Rail Module.
- The supply wires for DC version must be terminated using quick connectors.
- Extension cords may not be used.

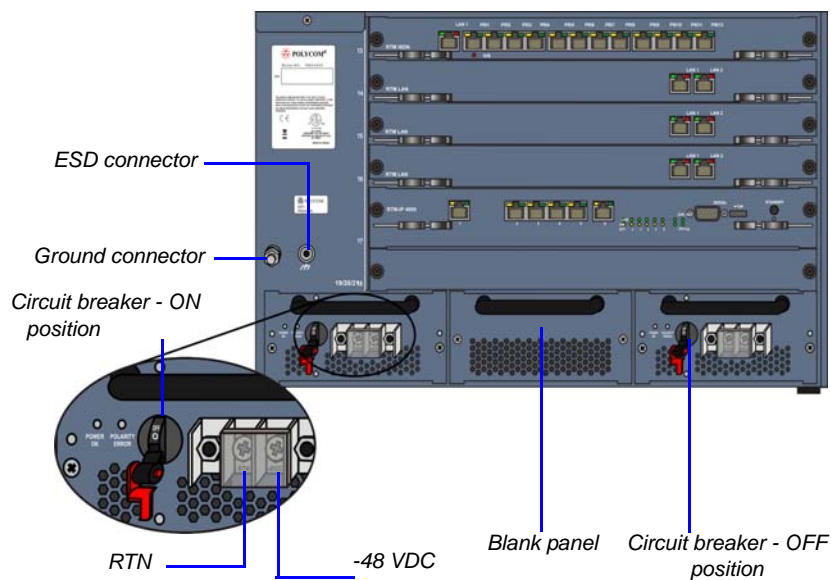

The center PRM slot/module is fitted with a blank panel and the slot cannot be used on a system with DC Voltage.

- 5 Connect the green or green-yellow wire to the system single-point M6x15 "Ground" bolt.



The rating of the protective earthing conductor should be a minimum of 10 AWG.

If the unit is rack mounted, the single-point ground on the MCU must be connected to the rack with a single conductor and fixed as to prevent loosening. When using bare conductors, they must be coated with an appropriate antioxidant compound before crimp connections are made. Tinned, solder-plated or silver plated connectors do not have to be prepared in this manner.

- 6 Replace the transparent plastic cap on the terminal block.



- 7 Turn ON the circuit breaker on each of the DC Power Rail Modules.

Types of DC Circuit Breakers installed on the RMX 4000

On the RMX, two types of circuit breakers may be installed:

- ON/OFF circuit breaker - Type A
- ON/OFF circuit breaker with locking mechanism - Type B

Table 1-8 Circuit Breaker Types

Type A	Type B
	

Connecting Cables to the RMX 4000

To connect the cables (AC and DC systems):



- LAN 4, LAN 5 and the Serial ports are only for debugging and not for customer use.
- Do not remove the protective plastic caps from LAN 1*, LAN 4 and LAN 5 ports.

- **RTM-IP 4000:**
 - Connect the Management Network cable to **LAN 2**.
 - Connect the Signaling cable to **LAN 3**.
 - Connect the Shelf Management cable to **LAN 6**.
- For each installed **RTM LAN** - Connect the LAN cable to **LAN 2**.
 - (Optional) Connect the LAN cable to **LAN 1**. With Multiple networks and LAN redundancy configurations, LAN 1 port is used. For more information, see *RMX 1500/2000/4000 Administrator's Guide*, "LAN Redundancy" on page [14-30](#) and "RMX Configuration" on page [14-52](#).

- For each installed **RTM ISDN**:
 - Connect the E1/T1 cables to their **PRI** Ports.
 - Connect the LAN cable to **LAN 1**.

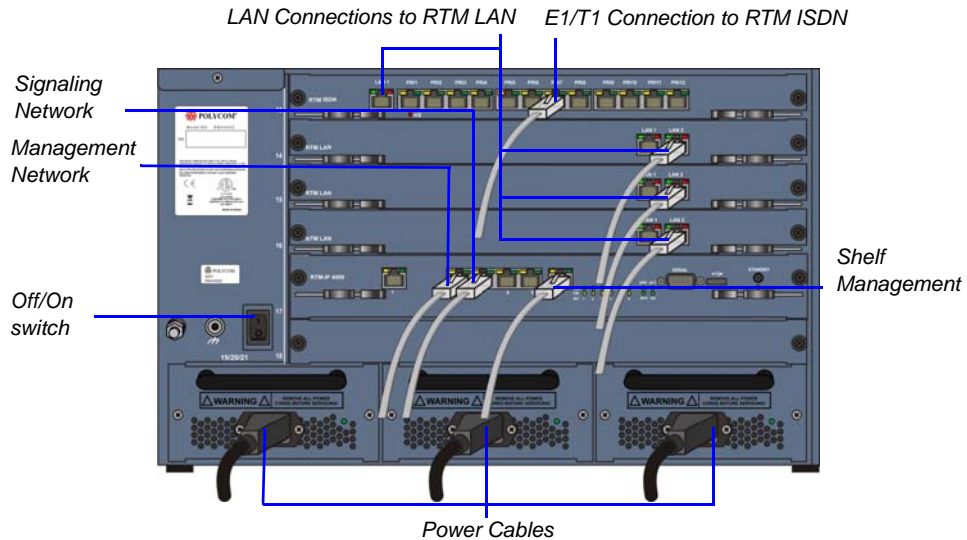

Figure 1-6 RMX 4000 Rear Panel View with AC Power and Communication Cables

For more information about specific card connections, see:

- "RTM-IP 4000" on page 1-28
- "RTM ISDN" on page 1-29
- "RTM LAN" on page 1-29

First-time Power-up

- 1 For first entry installation, you must insert the *USB key* containing the modified IP addresses in USB port on the RMX's back panel.



For more information about modifying the `lan.cfg` file on the USB key, and using the USB key, see the *RMX 1500/2000/4000 Getting Started Guide*, "Procedure 1: First-time Power-up" on page 2-15.

- 2 **AC System** - Turn ON the power by pressing on the power switch located on the rear panel of the RMX 4000.
DC System - Turn ON the Main that supplies power to the RMX and then turn ON the circuit breaker on the each of DC power rail modules.
 The parameters in the `lan.cfg` file are uploaded from the USB key to the RMX's memory and applied during the power-up sequence.
 System power-up sequence may take up to five minutes.
 During the First-time Power-up the red ERR LED on the RMX's front panel remains ON until both the *Management* and *IP Network Services* have been defined.
 When the RMX's configuration is completed (including the *Management* and *IP Network Services*), and if there are no *System Errors*, the green RDY LED on the CNTL module (on the RMX's front panel) turns ON.
- 3 Remove the *USB key*.

RMX 4000 Components

On the RMX 4000 components are located on both the front and rear of the MCU as listed in Table 1-9, "Polycom RMX 4000 Component Description".

For more information see the descriptions of the "RMX 4000 Front Panel" on page 1-17 and "RMX 4000 Rear Panel" on page 1-20.

RMX 4000 Front Panel

The front panel provides access to the RMX 4000 main CNTL 4000 module, Fabric Switch Module (FSM 4000), MPM+/MPMx modules, Power Supply drawers, Status LEDs, and Fan drawer. Figure 1-7 shows the front panel of the RMX 4000 fitted with AC Power supplies.

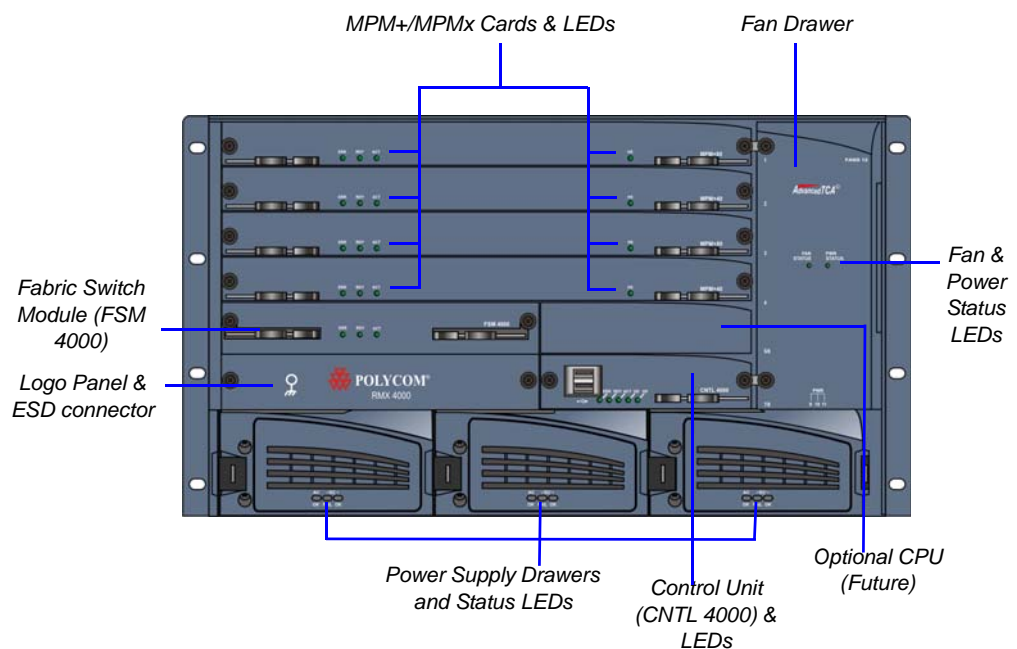

Figure 1-7 RMX 4000 AC Front View

Figure 1-8 shows the front panel of an RMX 4000 DC system.

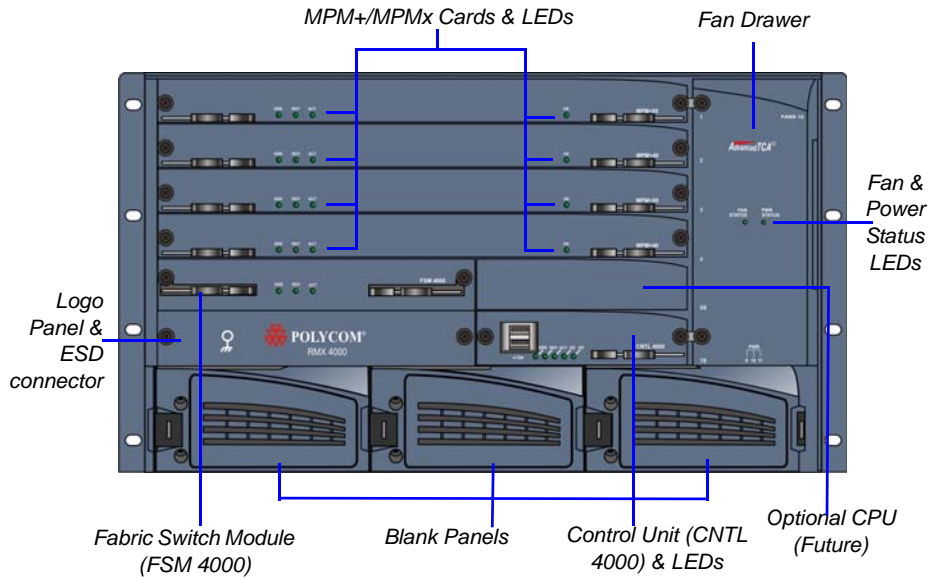

Figure 1-8 RMX 4000 DC Front View

Table 1-9 Polycom RMX 4000 Component Description

Component	Description
CNTL 4000 (CPU) Module	The CNTL4000 module controls and manages the RMX 4000. The CNTL 4000 module has an ComExpress Pentium-M 1.4GHz processor, a hard disk drive, Compact Flash and DDR RAM. The Operating System is Linux.
Fabric Switch Module (FSM 4000)	The Fabric Switch Module performs media processing functions on the RMX 4000 unit. This card is managed by the RTM-IP 4000.
AC/DC Power Supply Modules	The AC Power Supply drawers are located below the MPM+/MPMx Cards and are connected to the backplane by means of a power connector. Operating at 100-240 volts AC 50/60 Hz all power supplies have built-in load sharing capabilities. On systems with DC current, the Power Rail Module (PRM) provides direct current to the rear of the RMX through the backplane.
Fan Drawer	Eight fans are mounted sideways and stacked in a drawer. The drawer is connected to the Back-plane by a connector. Airflow is from right to left, and out the side of the MCU. Each time a board temperature sensor passes one of its thresholds an event is sent to the ShelfManager, whereupon an threshold alert is posted on the RMX Manager, and increases the fans speed. There are currently three sets of thresholds: Normal, Major and Critical. When the temperature reaches a critical threshold (and the fan's speed increase did not resolve the issue), the controller of the relevant board initiates a shut down.

Table 1-9 Polycom RMX 4000 Component Description (Continued)

Component	Description
Multi Processor Module+ (MPM+) Card	<p>The MPM+ cards, perform the various RTP, audio and video processing functions on the RMX 4000 unit. TI C6455 processors are at the core of each MPM+ card which are available in the following assemblies:</p> <ul style="list-style-type: none"> • MPM+20 (20 CIF resources) • MPM+40 (40 CIF resources) • MPM+80 (80 CIF resources) <p>Note: An MPM+ located (on the front panel) must face opposite (same slot level) an RTM LAN card (installed on the rear panel). For more information, see "RTM LAN" on page 1-23.</p>
Multi Processor Module x (MPMx) Card	<p>The MPMx cards, perform the various RTP, audio and video processing functions on the RMX 4000 unit. TI processors are at the core of each MPMx card which are available in the following assemblies:</p> <ul style="list-style-type: none"> • MPMx -S • MPMx -D <p>Note: An MPMx located (on the front panel) must face opposite (same slot level) an RTM LAN card (installed on the rear panel). For more information, see "RTM LAN" on page 1-23.</p>

MPM+ and MPMx Media Cards

The RMX unit can work with either MPM+ or MPMx (but not with both simultaneously) media cards. The card type installed in the system determines the *Card Configuration Mode*. ISDN support is the same for all card types.

G.719 audio algorithm is not supported with MPMx.

Card Configuration Mode Selection During Startup / Restart

When the MCU is started with Version 7.x installed and no media cards, the RMX is set to *MPMx Card Configuration Mode* by default.



- The RMX switches between *MPMx* and *MPM+* *Card Configuration Modes* when *MPM+/MPMx* cards are removed or swapped while the system is running.
- The switch between *Card Configuration Modes* occurs during the **next** restart.
- Installing or swapping *MPM+/MPMx* cards while the system is off will not cause a switch in the *Card Configuration Mode* when the system is restarted – it will restart in the *Card Configuration Mode* that was active previous to powering down.

RMX 4000 Rear Panel

The RMX 4000 rear panel contains the RTM-IP 4000 card and either (or both) RTM ISDN/RTM LAN card(s). In order for an MPM+/MPMx card to function (i.e. video) one of the RTM boards, either a LAN or ISDN card **MUST** be present in a rear panel slot opposite to an MPM+/MPMx card.

A single RTM-IP 4000 card must also be located on slot 17 in the rear of the RMX 4000. In addition, the rear panel houses the main AC power switch, AC Power Entry Modules (PEMs) or DC Power Rail Modules (PRMs), and additional communications ports.

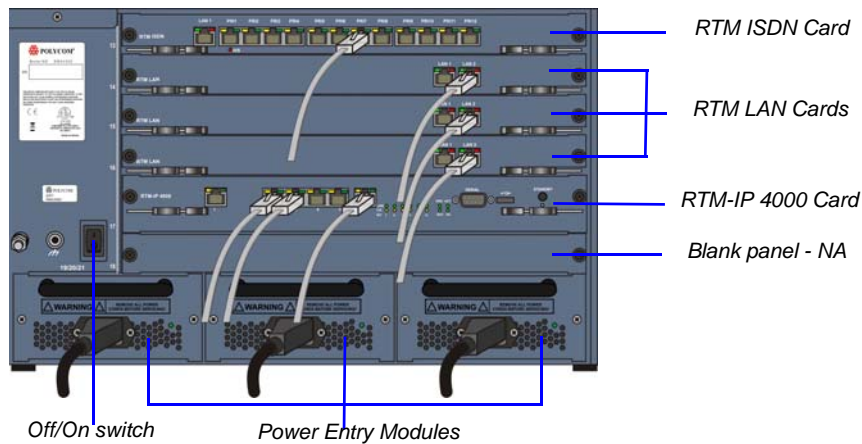

Figure 1-9 RMX 4000 AC Rear View

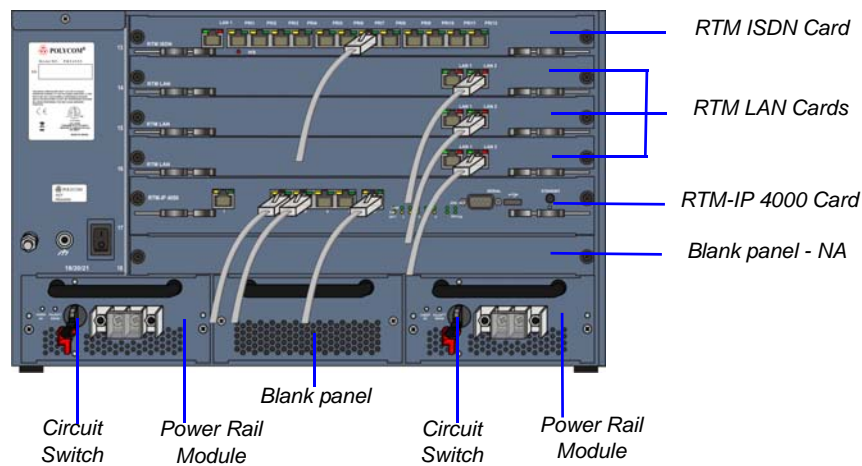

Figure 1-10 RMX 4000 DC Rear View



On some DC modules LED indications may not be present.

RTM-IP 4000

A single RTM-IP 4000 card provides system management based on the ATCA standard and connects to the backplane. Through the shelf manager, it controls and monitors the system fans and regulates the AC power supplies. This card contains an Ethernet Switch that manages the network of the system, routes data between the cards and components of the system and provides connectivity to external IP networks.



On the RMX 4000 when upgrading from MPM/MPM+ to MPMx on the RTM-IP 4000 all connections require **Ferrite** cables.

The RTM-IP 4000 card connections include:

- 6 LAN ports
- 1 Serial port (Future Use)
- 1 USB port

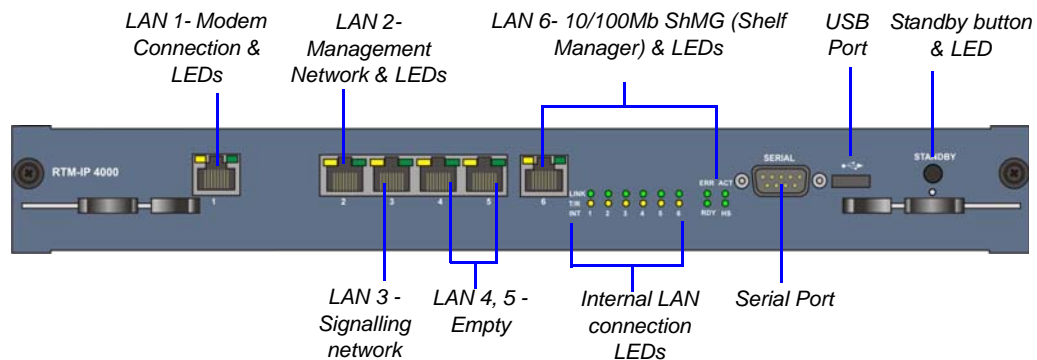

Figure 1-11 RMX 4000 RTM-IP 4000 Rear Panel Layout



- LAN 4, LAN 5 and the Serial ports are only for debugging and not for customer use.
- Do not remove the protective plastic caps from LAN 1, LAN 4 and LAN 5 ports.

The following items appear on the RMX 4000 rear panel:

Table 1-10 RMX 4000 Rear Panel - RTM-IP 4000 Component Description

Item	Description
LAN 1	Modem connection. Note: LAN 1 is covered with a plastic cap and should not be removed.
LAN 2 (CNTL 4000/ CPU 1)	Management network/Web Client connection.
LAN 3 (CNTL 4000/ CPU 1)	Signalling network, for Gatekeeper, Proxy or endpoint connections.
LAN 4-5 (CNTL 4000/ CPU 2)	Empty.
LAN 6	Shelf Manager connection.

Table 1-10 RMX 4000 Rear Panel - RTM-IP 4000 Component Description (Continued)

Item	Description
Serial	A 10/100 ShMG Shelf Manager connection. For debugging purposes only.
USB	USB key connection - TBD.
Standby button	Toggle between CPU activation and standby.

RTM ISDN

The RTM ISDN card connects directly to an MPM+/MPMx. The RTM ISDN card routes data between the MPM+/MPMx cards and components of the system, converts ISDN T1/E1 media to IP packets and provides connectivity to external ISDN networks.

The RTM ISDN card is installed on the rear panel of the RMX interfaces between the RMX unit and the ISDN/PSTN switch. In an RMX with a single MPM+/MPMx card – the RTM ISDN card must be installed in the rear panel slot on the same level as the MPM+/MPMx card. In an RMX with at least two MPM+/MPMx cards – the RTM ISDN card can be installed in any two rear panel card slots.

Up to two RTM ISDN cards can be installed in one RMX 4000. Up to a total of 14 E1 or 18 T1 PRI cables can be installed with two RTM ISDN cards.

Each RTM ISDN card includes the following connections:

- 1 LAN port
- 7 E1 or 9 T1 PRI lines that can be plugged into any of the 12 connections as shown in Figure 1-12.



E1 and T1 spans cannot be connected simultaneously to the same card, therefore, it is not possible to have a mixed E1 and T1 ISDN Network Service.

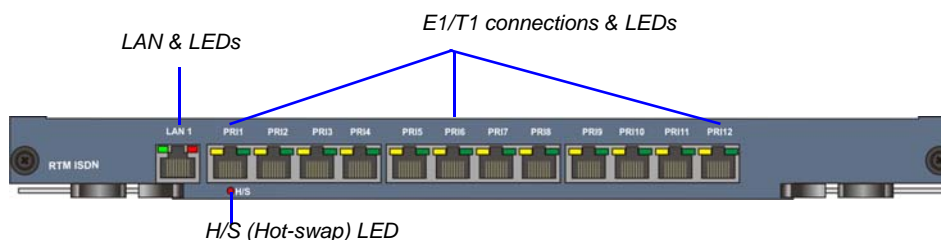

Figure 1-12 RMX 4000 RTM ISDN Rear Panel Layout

ISDN/PSTN Clock Source

Each RTM ISDN card has its own primary and secondary clock source. The first span to synchronize becomes the primary clock source and the second span to synchronize becomes the secondary clock source. This clock is used to synchronize ISDN spans only (it is not the system clock).

A single clock source triggers an alarm that can be turned off by setting the appropriate flag in the system configuration.

RTM LAN

The RTM LAN card routes data between the MPM+/MPMx cards and components of the system, sends media by IP packets and provides connectivity to external networks.

An RTM LAN card must connect directly to an MPM+/MPMx card. In an RMX with a single MPM+/MPMx card, the RTM LAN card must be installed in the rear panel slot on the same level as the MPM+/MPMx card.

Each RTM LAN card includes two LAN ports and a maximum of four RTM LAN cards can be installed on the RMX 4000.

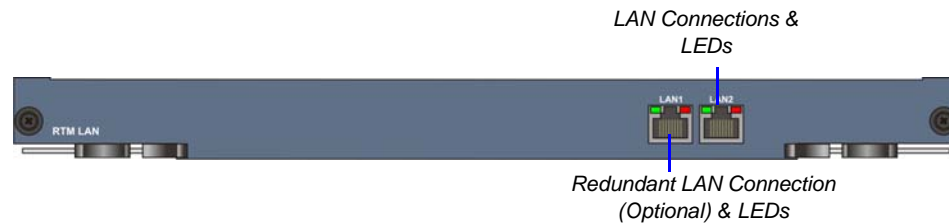

Figure 1-13 RMX 4000 RTM LAN Rear Panel Layout



For more information see *RMX 1500/2000/4000 Administrator's Guide*, "LAN Redundancy" on page 14-30.

AC Power Entry Module (PEM)

An AC PEM includes a power inlet, EMI filter and backplane connectors. Power input to the system is fed via a PEM (Power Entry Module) through backplane into the power supply. Each AC power module has its own dedicated power cable. The ON/OFF switch on the rear of the RMX activates any power module installed on the RMX. An AC system has three AC PEMs, one for each power module. On failure, both AC power supplies and PEMs are hot swappable.

DC Power Rail Module

A DC power rail module includes a power inlet, circuit breaker, EMI filter and backplane connectors. Power input to the system is fed via a power rail through backplane into the power supply. Each DC power rail has its own dedicated power cable. The circuit switch on the rear of the RMX activates independently any power rail installed on the RMX. An DC system has two DC rails, one for each power rail. On failure, a DC power rail is field replaceable and the RMX must be switched OFF from the two circuit switches and the mains.

Component Slot Allocation

On the RMX™ 4000, components have been assigned dedicated slots as defined in Table 1-11. Slot numbers are located on both the front and rear of the RMX™ 4000.

Table 1-11 RMX™ 4000 Slot Numbering

Slot ID/No.	Card/Component	Requirement
1-4	MPM+/MPMx Cards	Mandatory: At least 1 MPM+/MPMx card is required. Each media card also requires either an RTM ISDN or an RTM LAN card.
5	Fabric Switch Module (FSM 4000)	Mandatory
6	CPU 2	Not Available (NA)
7	Logo Panel	Not Available (NA)
8	CTNL 4000 unit (CPU 1)	Mandatory
9-11	AC Power Supply	An RMX with AC power has 3 power supplies installed. A 3rd power supply is redundant (n+1). Note: Not used with DC powered systems. DC powered systems receive Direct Current from the power rail .
12	Fan Drawer	Mandatory
13-16	RTM ISDN/RTM LAN	Either an RTM ISDN or an RTM LAN card is mandatory in combination with a Media card. The RTM ISDN/RTM LAN board must be inserted in a slot opposite any MPM+/MPMx card.
17	RTM-IP 4000	Mandatory
18	Blank Panel	Not Available (NA)
19-21	Power Modules 	Mandatory: With AC power, three power supplies are installed, with the 3rd redundant. With DC power, two power supplies are installed with the 2nd redundant. The center slot (#20) on the rear of the RMX 4000 is disabled and is fitted with blank panel. Note: Protective bonding conductor size is 14AWG (1.5mm) within the Power Entry Model.

RMX 4000 LEDs

The RMX includes LEDs located on the front panel and rear panel. In the front panel, the LEDs reflect the state of the components. The LEDs on the rear panel indicate the state of the external connections and the status of the RTM-IP 4000 card.

RMX 4000 Front Panel LEDs

The following items appear on the RMX 4000 front panel:

Table 1-12 RMX 4000 Front Panel LED's

Component	LED ID	LED Color	Description
Fan Status		Green	OK.
		Red	Warning - Fan or power failure.
Power Module/Rail Status (AC only)	AC	Green	OK.
		Red	Error - Problem with power supply. When the power cable is unplugged, the FAIL LED is lit 2-3 seconds before turning OFF.
	DC (OK)	Green	OK.
	DC (FAIL)	Red	Error - Problem with power supply. When the power cable is unplugged, the FAIL LED is lit 2-3 seconds before turning OFF.
		OFF - all LED's	In case of a power failure (main/cable/module) all LED's are OFF.
Fabric Switch Module (FSM 4000)	ERR	Red	ON - Major error on card. Flashes - During card startup.
	RDY	Green	ON - The card has completed startup successfully. Flashes - During card startup.
	ACT	Orange	ON - At least one participant is connected to a conference. Flashes - During card startup.

Table 1-12 RMX 4000 Front Panel LED's (Continued)

Component	LED ID	LED Color	Description
MPM+/MPMx Card	ERR	Red	ON - Major error on card. Flashes - During card startup.
	RDY	Green	ON - The card has completed startup successfully, after the ERR, RDY & ACT LED's have stopped flashing. Flashes - During card startup.
	ACT	Amber	ON - At least one participant is connected to a conference. Flashes - During card startup.
	HS	Blue	Flashes - Shut down process initiated by lightly pulling the CPU ejector levers. This LED flashes in synchronization with the CNTL 4000's card's HS LED. ON - Card is in a power down mode. Card removal Initiated - The card can be removed safely once the CPU ejector levers are fully open. Card Insertion Initiated - If during the startup phase the blue HS LED remains lit, please ensure that the card is properly seated in the chassis. If this problem persists, contact your next level of support.

Table 1-12 RMX 4000 Front Panel LED's (Continued)

Component	LED ID	LED Color	Description
CNTL 4000 Unit	ERR	Red	ON - Major system error. In case of an active alarm this light is ON, and the RDY green is OFF.
			OFF - Normal.
			Flashes - During system startup.
	RDY	Green	ON - CPU card has successfully completed startup. This light turns green after completing the entire system configuration.
			OFF - Turns OFF when the ERR red LED is activated.
			Flashes - During system startup.
	ACT	Amber	ON - At least one endpoint is connected to the system. Flashes - During system startup.
	HD	Red	OFF - Normal.
			Flashes - Hard disk is active.
	HS	Blue	Flashes - Indicates when the power down process is initiated on an MPM+/MPMx card. This LED flashes in synchronization with the MPM+/MPMx's cards HS LED. OFF - Normal
			ON - CPU may be removed.

RMX 4000 Rear Panel LEDs

RTM-IP 4000

The following LEDs appear on the RTM-IP 4000 card:

Table 1-13 RTM-IP 4000 LEDs

Component	LED Name	LED Color	Description
LAN 1 LEDs	LNK	Green	ON with an active network connection, flickers with Packet activity.
	1Gb	Green	ON with a 1Gb online connection, flickers with Packet activity.
LAN 2-5 LEDs	LNK	Amber	ON with a 100Mb online connection.
	ACT	Green	ON with network connection, flickers with Packet activity. OFF-1Gb or no connection.
LAN 6 LEDs 10/100Mb ShMG	LNK	Amber	ON - online connection, flickers with Packet activity. OFF - No Link.
	100	Green	ON - Connection 100Mb. OFF - Connection is not 100Mb or No Link.
INT LEDs (No.) 1-6	LINK	Green	ON with an active network connection, flickers with Packet activity.
	T/R	Amber	ON with a 1Gb online connection, flickers with Packet activity.
STANDBY LED		Green	Not supported. ON - Lit when the system is switched on.
ShMG (Shelf Manager) LEDs	ERR	Red	ON - Major error on RTM-IP 4000 card. Flashes - During system startup.
	ACT	Amber	ON - Packet flow to and from the MCU chassis. Flashes - During system startup.
	RDY	Green	ON - RTM-IP 4000 card has successfully completed startup. Flashes - During system startup.
	HS	Blue	Hot Swap not supported. OFF - Normal. Flashes for a second during initial power up.

RTM LAN

The following LEDs appear on the RTM LAN:

Table 1-14 RMX 4000 RTM LAN LEDs

Function Name	LED Name	LED Color	Description
LAN 1 & 2 LEDs	1 Gb	Amber	ON when 1Gb connection is online, flickers with Packet activity.
	LNK	Green	ON with an active network connection, flickers with Packet activity.
H.S. LED		Blue	OFF - Normal.
			Flashes - During the startup of a media card and control 4000 unit. Also flashes when the RTM LAN card is powered down.
			ON - RTM LAN card may be removed.

RTM ISDN

The following LEDs appear on the RTM ISDN:

Table 1-15 RMX 4000 RTM ISDN LEDs

Function Name	LED Name	LED Color	Description
LAN 1 LEDs	1 Gb	Amber	ON when 1Gb connection is online, flickers with Packet activity.
	LNK	Green	ON with an active network connection, flickers with Packet activity.
PRI LEDs		OFF	Span x not in use.
		Green	Span x is OK.
		Red	Span x red alarm (LOS - Loss of Signal)
ShMC LED	HS	Blue	OFF - Normal.
			Flashes - During the startup of a media card and control 4000 unit. This LED is activated when the MPM+/MPMx card Hot Swap functionality initiates a power off routine on the MPM+/MPMx cards.
			ON - Power on the RTM ISDN card has been switched OFF. This LED is activated by the card when the MPM+/MPMx's card Hot Swap functionality powers off the MPM+/MPMx cards.

DC Power Rail LEDs

The following LEDs appear on the DC Power Rail:

Table 1-16 RMX 4000 DC Power Rail LEDs

Function Name	LED Name	LED Color	Description
DC Power	POWER OK	Green	ON - Power input is within required voltage specifications: -38.5V to -70V
		Not lit	OFF - No LED indication, Power supply or power failure.
	POLARITY ERROR	Red	Polarity Error. Switch the polarity of the two cables connected to the DC power supply!

Component Replacement

The RMX 4000 is designed with ease of maintenance in mind. Most components are swappable and are accessible directly via the front panel or the rear panel.



The MPM+/MPMx, power supplies and Fan tray are Hot Swappable. The Fan tray must be replaced immediately or the temperature spike in the RMX shall initiate a shutdown. The RTM-IP 4000, RTM ISDN, RTM LAN, Fabric Switch Module (FSM) 4000 and the CTNL 4000 **are not** Hot Swappable. System shutdown is required when replacing the RTM-IP 4000, RTM ISDN, RTM LAN, FSM 4000 and the CTNL 4000.

The following components can be replaced when they are faulty:

- CNTL 4000 Module, see "*Replacing the CNTL 4000 Module*" on page [2-2](#).
- AC Power Supply Modules, see "*Replacing an AC Power Supply Module*" on page [2-3](#).
- AC Power Entry Modules, see "*Replacing an AC Power Entry Module (PEM)*" on page [2-4](#).
- DC Power Rail Modules, see "*Replacing a DC Power Rail Module (PRM)*" on page [2-5](#).
- Fan drawer, see "*Replacing the Fan Drawer*" on page [2-7](#).
- Adding an Air Filter, see "*Inserting an Air Filter (Optional) in the Fan Drawer*" on page [2-8](#).
- MPM+/MPMx card. This card is hot-swap enabled. See "*Removing an Faulty MPM+/MPMx Card*" on page [2-9](#).
- RTM ISDN card, see "*Replacing the RTM ISDN Card*" on page [2-11](#).
- RTM-IP 4000 card, see "*Replacing the RTM-IP 4000*" on page [2-12](#).
- RTM LAN card, see "*Replacing the RTM LAN*" on page [2-13](#).
- Fabric Switch Module (FSM 4000), see "*Replacing the Fabric Switch Module (FSM 4000)*" on page [2-14](#).



Warning!

- All maintenance tasks are to be performed by qualified, authorized personnel.
- Use only replacement parts supplied by your dealer.
- Follow all procedures. Do not skip any steps.

Before replacing parts:

- To ensure a part needs replacing, complete the troubleshooting procedures.
- Identify exactly which part needs replacing.
- Make sure you have the correct replacement part on hand.
- Make sure you are using proper ESD equipment, to prevent damage to the system.



Note! On all cards, if during the startup phase the blue HS LED remains lit, please make sure that the card is properly seated in it's slot. If this problem persists, contact your next level of support.

Using the Modified PMC Compatible Ejector Lever

On the RMX 4000 most components are fitted with identical ejector levers that are used to release or fasten the component's to their slot.

This ejector lever can be moved to three positions:

- **Closed/Locked** - Ejector lever(s) are gently pushed up against the card's panel and is locked. Ensure that the lock catch is in the standard closed position (shifted to the right as shown below).

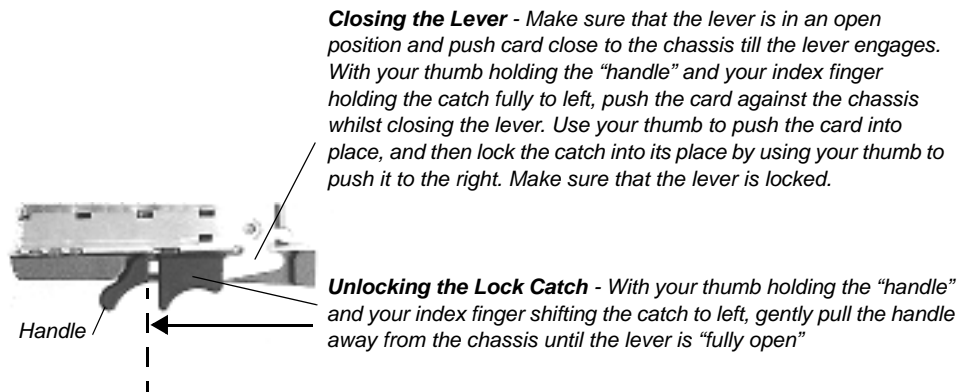

- **Partially Open** - For card powering down mode. Partially open the ejector lever(s) until the blue *HS* LEDs on the card and the *Control Unit* start flashing. When the HS LED is constantly lit the card is in a powered down mode and you can remove the card.



Warning!

Once the removal sequence is initiated the process cannot be terminated and the HS led flashes when activated.

- **Fully Open** - In this position the card is released from the MCU housing and can be removed.



Lever Fully Open - Pull the lever handle(s) to a fully open position (approx. 70 degrees), as shown here

Replacing the CNTL 4000 Module

The CPU module is the management system of the RMX 4000. Use the following procedure to replace a CNTL 4000 Module:

- 1 Ensure that the power switch/circuit switch on the RMX 4000 is turned OFF (O).
- 2 Unscrew the captive screws on the front panel of the CNTL 4000 Module that secure the module to the chassis.
- 3 Use the metal ejector lever to pull the CNTL 4000 Module out of its slot in the Backplane.

- 4 Carefully slide the CNTL 4000 Module out through the front panel.

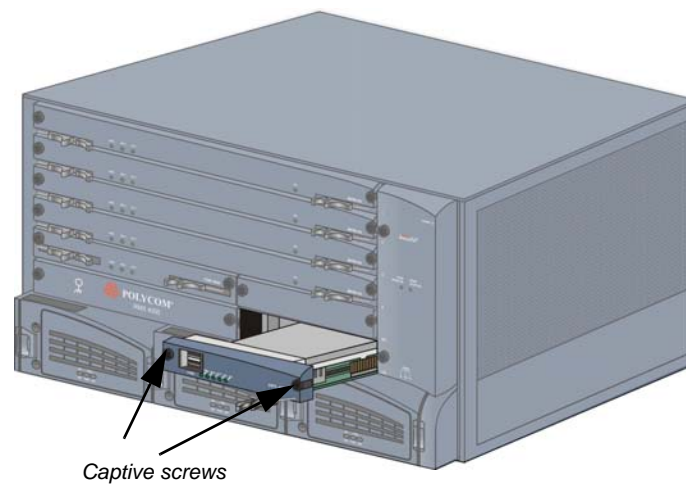

- 5 On the CNTL 4000 Module to be installed, move the ejector lever to the fully open position.
- 6 Slide in the replacement CNTL 4000 Module.
- 7 Push the CNTL 4000 Module firmly into the Backplane, making sure it is properly seated in its slot.
- 8 Ensure that the metal ejector lever is fully retracted into it's housing.
- 9 Tighten the captive screws on the front panel of the CNTL 4000 Module that secure the CNTL 4000 Module to the chassis.
- 10 Turn ON the RMX 4000.

Replacing an AC Power Supply Module

Two units supply power to the RMX 4000 (3rd optional - AC only), each unit with its own power cord. Use the following procedure to replace a Power Supply unit:



Please verify the type of power supply used on your RMX 4000. Do not insert a different type of power supply than the current type installed on your system.

- 1 Unscrew the captive screws on the front panel of the Power Supply unit that secures the unit to the chassis.

- 2 Using your right hand, press your thumb on the pressure latch and with your fingers inserted in the hand grip (on top), pull the Power Supply unit out.

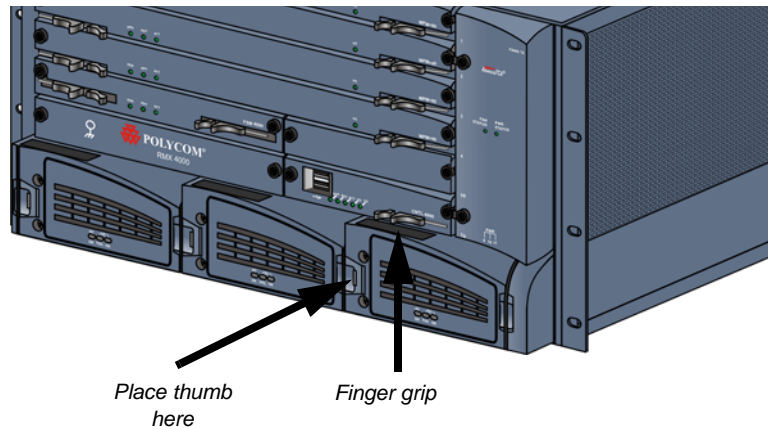

- 3 Carefully slide the Power Supply unit out from the front slot.

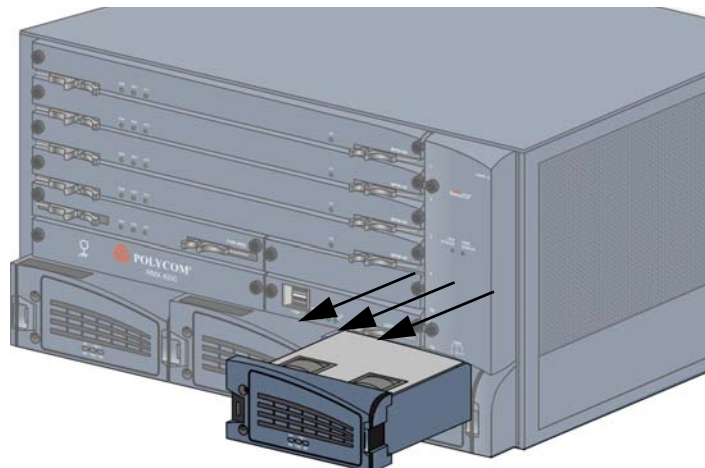

- 4 Slide in the replacement Power Supply unit.
- 5 Push the Power Supply unit firmly into the Backplane, making sure it is properly seated in its slot, and that the latch is in a locked position.
- 6 Tighten the captive screws on the front panel of the Power Supply unit to the chassis.

Replacing an AC Power Entry Module (PEM)

On the rear of the RMX three AC PEM's are fitted, each with their own power cord.

Use the following procedure to replace a Power Entry Module (PEM):



Please verify the type of PEM used on your RMX 4000. Do not insert a PEM of a different type on your system.

- 1 Unplug the Power cord connected to the failed PEM unit.
- 2 Unscrew the captive screws on the rear panel of the PEM unit that secures the unit to the chassis.

- 3 Using the handle fitted to the PEM, pull the PEM unit out.
- 4 Carefully slide the PEM unit out from the rear slot.



- 5 Slide in the replacement PEM unit.
- 6 Push the PEM unit firmly into the Power Supply, making sure it is properly seated in its slot.
- 7 Tighten the captive screws on the rear panel of the PEM unit to the rear chassis.

Replacing a DC Power Rail Module (PRM)

On the rear of the RMX 4000 two DC Power Rail Modules are fitted, each with their own power cord.

Use the following procedure to replace a DC Power Rail Module:



- Please verify the type of PRM used on your RMX 4000. Do not insert a Power Rail Module of a different type on your system.
- When replacing a DC Power Rail Module:
On the Mains, disconnect the electricity that supplies direct current running through the power cable to the failed DC PRM.

- 1 Turn OFF the circuit switch on the each of the DC PRMs and from the Mains.
- 2 Verify that DC PRM unit you are about to replace on the RMX 4000 is not HOT or has any Live current feed.
- 3 Remove the plastic cap fitted to the Terminal block that protects the direct current connections.
- 4 Using a star screw driver, disconnect the two wires connected to the Terminal block (-48 VDC & RTN) of the failed DC PRM unit.
- 5 Unscrew the captive screws on the rear panel of the PRM unit that secures the unit to the chassis.

- 6 Using the handle fitted to the DC PRM, pull and slide the PRM unit out.



- 7 Slide in the replacement PRM unit.
- 8 Push the PRM unit firmly into the chassis, making sure it is properly seated in its slot.
- 9 Tighten the captive screws on the rear panel of the PRM unit to the rear chassis.
- 10 Connect the black wire into the -48 VDC terminal block and the red wire to the RTN terminal block and tighten the two screws.
- 11 Replace the transparent plastic cap on the terminal block.
- 12 Turn ON the Main that supplies power to the RMX.
- 13 Turn ON the circuit breaker on each of the DC Power Rail Modules.

Replacing the Fan Drawer

Eight fans are mounted in the Fan drawer, where the airflow is from right to left. Should one of these fans fail as indicated by a Fan LED, you are required to replace the Fan drawer.

- 1 Unscrew the captive screws on the front panel of the Fan drawer secured to the Fan chassis.
- 2 Use the finger grip, pull the Fan drawer out of its slot in the Backplane.

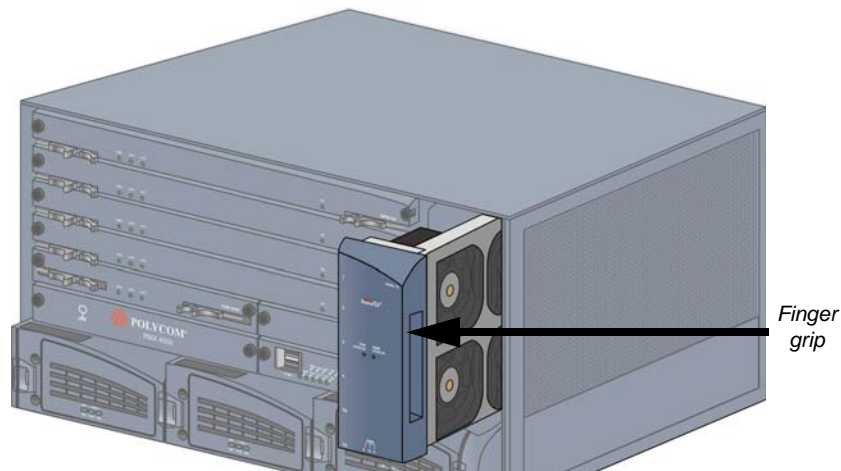

- 3 Carefully slide the Fan drawer out through the front panel.



Warning!

The Fan drawer can be replaced when the RMX unit is ON, however a replacement drawer must be inserted immediately. The temperature increase is detected by the system, when critical, a system shutdown is initiated.

- 4 Slide in the replacement Fan drawer.
- 5 Push the Fan drawer firmly into the Backplane, making sure it is properly seated in its slot.
- 6 Tighten the captive screws on the front panel of the Fan drawer to the chassis.

Inserting an Air Filter (Optional) in the Fan Drawer

In the fan drawer, an Air Filter can be added as an option. You must order this part through your next level of support.

- 1 Ensure that the power switch/circuit switch on the RMX 4000 is turned OFF (O).



Warning!

The air filter cannot be replaced when the RMX 4000 unit is ON.

- 2 Unscrew the captive screws on the front panel of the Fan drawer secured to the Fan chassis.
- 3 Use the finger grip, pull the Fan drawer out of its slot in the Backplane.

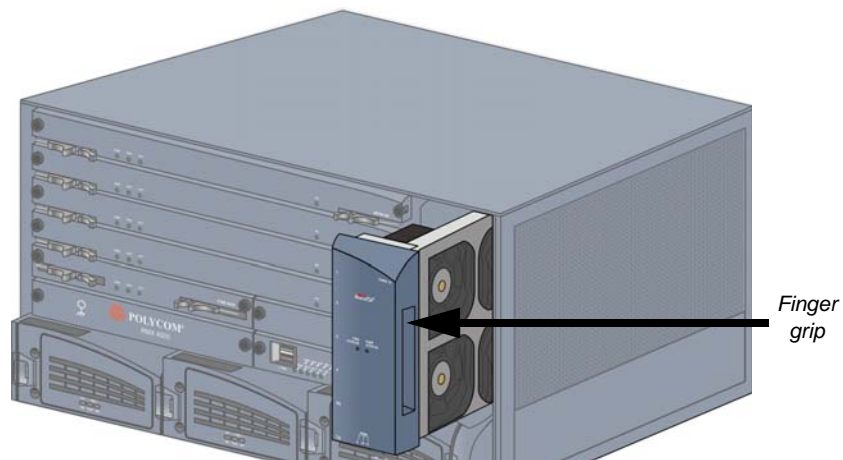

- 4 Carefully slide the Fan drawer out through the front panel.
- 5 Open the filter tray, by unscrewing two screws on the tray.

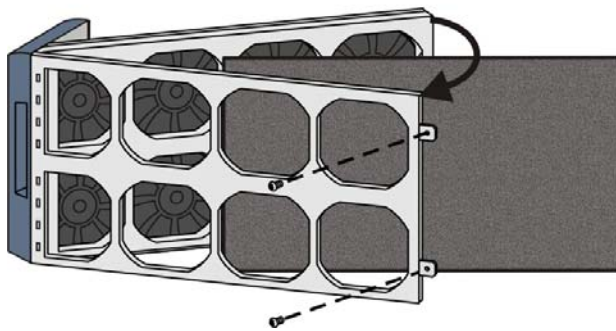

- 6 Remove the existing air filter.
- 7 Insert a new or cleaned air filter into the filter tray.
- 8 Close the filter tray, by tightening the two screws on the tray.
- 9 Insert and slide in the Fan drawer.

- 10 Push the Fan drawer firmly into the Backplane, making sure it is properly seated in its slot.
- 11 Tighten the captive screws on the front panel of the Fan drawer to the chassis.
- 12 Turn ON the RMX 4000.



It is recommended that the air filter be replaced or cleaned every six months.

Removing an Faulty MPM+/MPMx Card



On the RMX 4000 when upgrading from MPM/MPM+ to MPMx on the RTM-IP 4000 all connections require **Ferrite** cables.

Removing the MPM+/MPMx Card from the MCU

All MPM+/MPMx cards can be installed or removed while the RMX 4000 is powered on and operating.

Prior to removing an MPM+/MPMx card the captive screws must be unscrewed and the ejector levers must be opened to initiate a “power down” on the card.

- 1 If applicable, loosen the captive screws and remove the slot cover.
- 2 Power down the card by partially opening the ejector levers until the blue *HS* LED on the card and the *Control Unit* start to flash.



Warning!

Once the removal sequence is initiated the process cannot be terminated and the *HS* LED flashes.

- 3 The power off sequence for the interconnected MPM+/MPMx and RTM ISDN cards are initiated as follows:
 - All participant connections on the card are disconnected.
 - A fault is generated on the system.
 - For each disconnected participant, a participant disconnection event is written to the CDR with the disconnection cause *Disconnected by Operator*.
 - New participant connections are blocked when the card is removed.
 - If an RTM ISDN card is connected to the MPM+/MPMx card it is also powered off and all ISDN and PSTN participants are disconnected.
 - When an RTM ISDN card is removed, its resources are deducted from the Resource Report.
 - A *Log File* entry is written indicating MPM+/MPMx card removal.
 - Port usage is re-calculated and the *Port Gauges* and *Video/Voice Port Configuration* dialog box are updated.
- 4 When the blue *HS* LEDs on the MPM+/MPMx, RTM ISDN and Control Unit stop flashing and remain lit, unscrew the captive screws and move the ejector levers to their fully open position and remove the MPM+/MPMx card.

- 5 Carefully slide the MPM+/MPMx card out through the front panel.

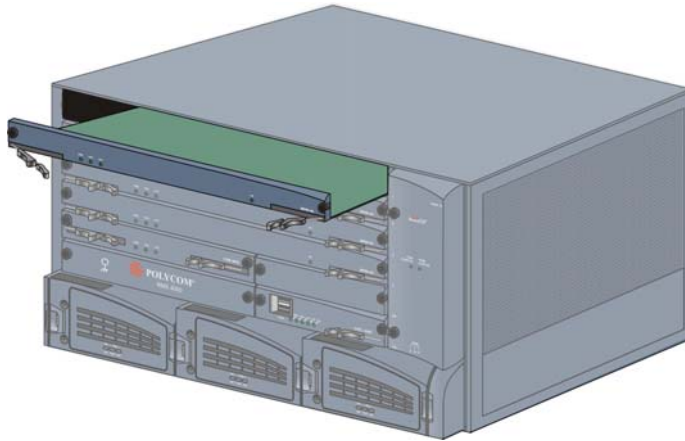

Installing or Replacing MPM+/MPMx Card on the RMX 4000



On the RMX 4000 when upgrading from MPM+ to MPMx on the RTM-IP 4000 all connections require **Ferrite** cables.

- 1 If applicable, loosen the captive screws and remove the slot cover.
- 2 On the card to be installed, move the ejector levers to their full open position.
- 3 Insert the card into the slot until the ejector levers touch the front edge of the card cage.
- 4 Push the ejector levers to their closed position and tighten the captive screws on each side of the card, securing the MPM+/MPMx card to the RMX.

The blue HS LEDs on the MPM+/MPMx card and the *Control Unit* start flashing and the power on cycle for the card is initiated:

- The card's resources are added to the system resources list
- The number of available ports on the RMX is increased to the current CFS license level
- Port usage is re-calculated and the *Port Gauges* and *Video/Voice Port Configuration* are updated

When the power on cycle of the MPM+/MPMx card is completed, the blue HS LEDs will turn OFF. The green RDY LED on the MPM+/MPMx card switches on and remains lit.

Replacing the RTM ISDN Card

- 1 Ensure that the power switch/circuit switch on the RMX 4000 is turned OFF (O).
- 2 Remove the cables connected to the card.
- 3 Unscrew the captive screws that fasten the card to the MCU.
- 4 Remove the RTM ISDN card. Use the metal ejector levers to pull the RTM ISDN card out of its slot in the backplane.
- 5 Carefully slide the RTM ISDN card out through the front panel.
- 6 On the card to be installed, move the ejector levers to their fully open position.

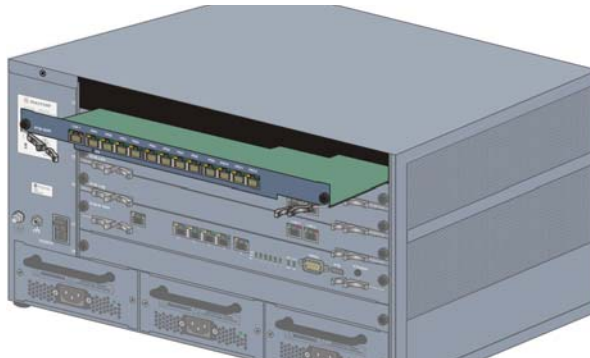

- 7 Slide in the replacement RTM ISDN card.
- 8 Insert the card into the slot until the ejector levers touch the front edge of the card cage.
- 9 Push the ejector levers to their fully closed position.
- 10 Tighten the captive screws on each side of the rear panel of the card, securing the RTM ISDN card to RMX.
- 11 Connect the RJ-45 terminated PRI cables into any of the slots labeled PRI1 - PRI12:

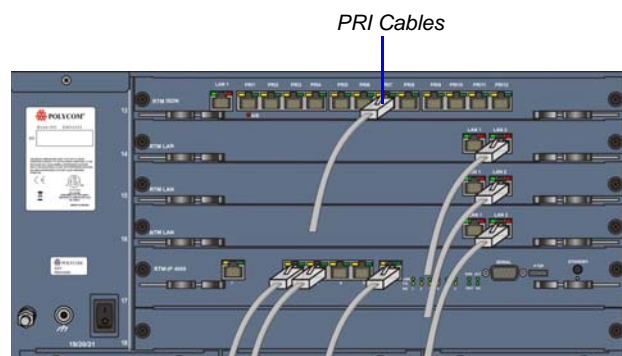

7 E1 or 9 T1 cables can be connected to each RTM ISDN card, up to a total of 14 E1 or 18 T1 PRI cables when a maximum of two RTM ISDN cards are installed.

- 12 Turn ON the RMX 4000.

Replacing the RTM-IP 4000



RTM-IP 4000 connections require **Ferrite** cables when connecting to MPMx cards.

The RTM-IP 4000 card on the rear of the RMX 4000 provides connectivity to all the MCU modules. Use the following procedure to replace the RTM-IP 4000 card:

- 1 Ensure that the power switch/circuit switch on the RMX 4000 is turned OFF (O).
- 2 Remove the cables connected to the card.
- 3 Unscrew the captive screws on the rear panel of the RMX 4000 that secure the RTM-IP 4000 card.
- 4 Use the metal ejector levers to pull the RTM-IP 4000 card out of its slot in the backplane.

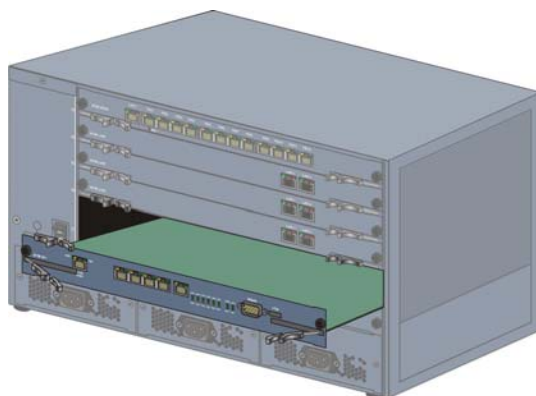

- 5 Carefully slide the RTM-IP 4000 card out through the rear panel.
- 6 On the card to be installed, move the ejector levers to their fully open position.
- 7 Slide in the replacement RTM-IP 4000 card.
- 8 Push the RTM-IP 4000 card firmly into the backplane, making sure it is properly seated in its slots.
- 9 Ensure that the metal ejector levers are fully retracted into their housings.
- 10 Tighten the captive screws on the rear panel of the RMX 4000 that secure the RTM-IP 4000 card.
- 11 Reconnect the cables.
- 12 Turn ON the RMX 4000.

Replacing the RTM LAN

The RTM LAN card on the rear of the RMX 4000 provides connectivity to all the MCU modules. Use the following procedure to replace the RTM LAN card:

- 1** Ensure that the power switch/circuit switch on the RMX 4000 is turned OFF (O).
- 2** Remove the cables connected to the card.
- 3** Unscrew the captive screws on the rear panel of the RMX 4000 that secure the RTM LAN card.
- 4** Use the metal ejector levers to pull the RTM LAN card out of its slot in the backplane.

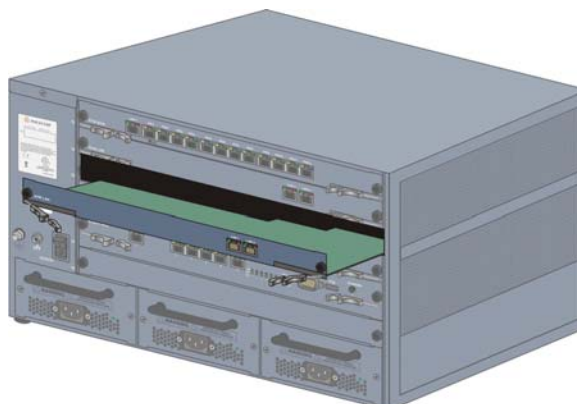

- 5** Carefully slide the RTM LAN card out through the rear panel.
- 6** On the card to be installed, move the ejector levers to their fully open position.
- 7** Slide in the replacement RTM LAN card.
- 8** Push the RTM LAN card firmly into the backplane, making sure it is properly seated in its slots.
- 9** Ensure that the metal ejector levers are fully retracted into their housings.
- 10** Tighten the captive screws on the rear panel of the RMX 4000 that secure the RTM LAN card.
- 11** Reconnect the cables.
- 12** Turn ON the RMX 4000.

Replacing the Fabric Switch Module (FSM 4000)

- 1 Ensure that the power switch/circuit switch on the RMX 4000 is turned OFF (O).
- 2 Loosen the captive screws that fasten the module to the MCU.
- 3 Remove the Fabric Switch Module (FSM 4000). Use the metal ejector levers to pull the Fabric Switch Module (FSM 4000) out of its slot in the backplane.
- 4 Carefully slide the Fabric Switch Module (FSM 4000) out through the front panel.

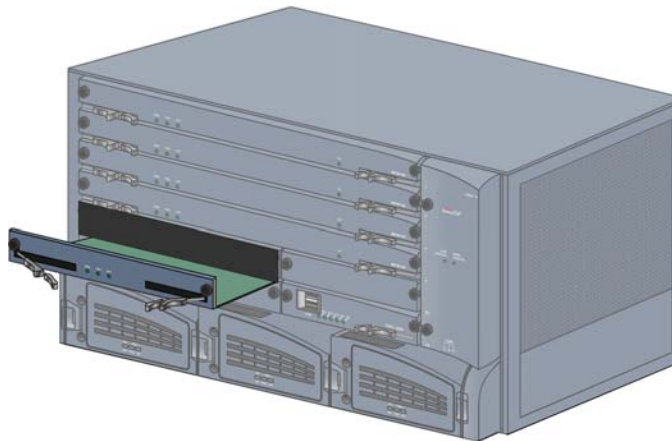

- 5 On the card to be installed, move the ejector levers to their fully open position.
- 6 Slide in the replacement Fabric Switch Module (FSM 4000).
- 7 Push the Fabric Switch Module (FSM 4000) firmly into the backplane, making sure it is properly seated in its slots.
- 8 Ensure that the metal ejector levers are fully retracted into their housings.
- 9 Tighten the captive screws on the rear panel of the RMX 4000 that secure the Fabric Switch Module (FSM 4000).
- 10 Turn ON the RMX 4000.

Appendix A

Pin Assignment

PRI Port Assignment

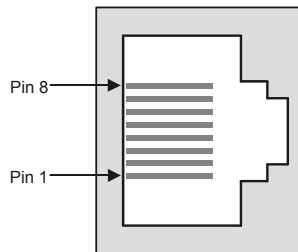

Table A-1: PRI Port Assignment

Pin	Signal Name
1	Receive Ring
2	Receive Tip
3	No connection
4	Transmit Ring
5	Transmit Tip
6	No connection
7	No connection
8	No connection

